



Acton Lane, W4

£549,950

Investment purchase offered to market with tenant in situ is this recently refurbished split-level apartment with an open plan kitchen/reception with wood flooring, a bedroom and a further mezzanine area above.

Located very close to Chiswick Park underground station and under half a mile from all the amenities Chiswick High Road has to offer.

Features

Investment Purchase
Recently Refurbished
Split-Level
Two Bedrooms
One Bathroom
Transport Links

Acton Lane,
London, W4

Second Floor

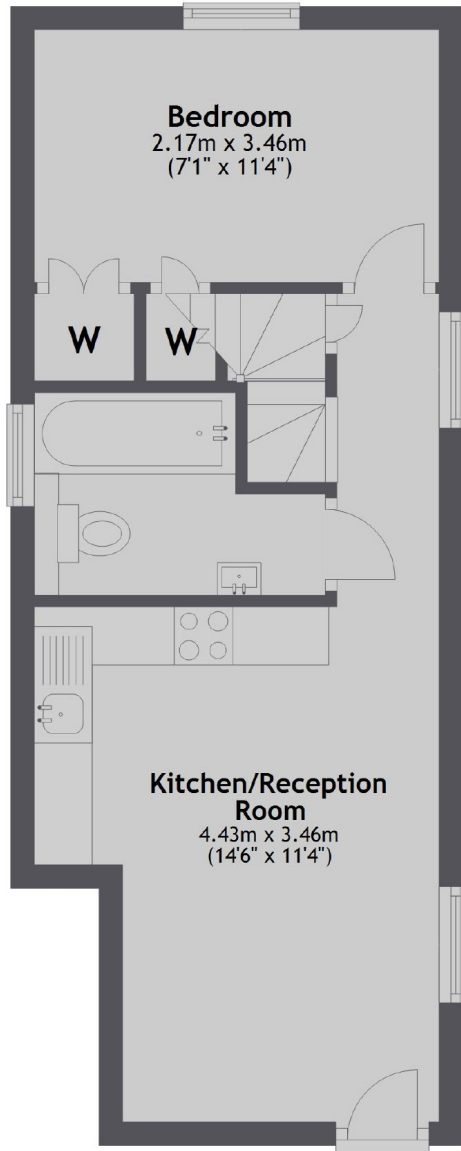

Top Floor

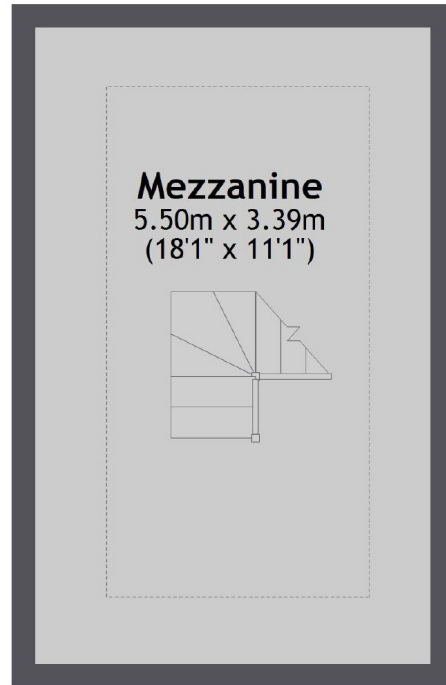

Total area: approx. 49.4 sq. metres (532.1 sq. feet)