



MAP estate agents
Putting your home on the map

**Chywoone Crescent,
Newlyn, Penzance**

**Guide Price £130,000
Leasehold**





**Chywoone Crescent,
Newlyn, Penzance**

**Guide Price £130,000
Leasehold**

Property Introduction

Accessed by its own private door and staircase, this light and airy apartment offers a fantastic open plan living space with kitchen area to one corner, two bedrooms and bathroom. The apartment gains sea glimpses from the living room.

The property is warmed via gas central heating to radiators and is double glazed.

To the front of the property there is a generous lawned garden which is enclosed by picket fencing and unrestricted street parking is available on the crescent. Offered for sale with NO CHAIN.

Location

Newlyn has a rich history in the fishing industry and many boats land their catch of the day at the harbourside. Newlyn has become a popular place to visit as it has a selection of art galleries along with a cinema and a number of restaurants serving fine food.

You can also enjoy the sea front and take the fifteen minute level walk into the larger market town of Penzance. Penzance has a wide range of retail outlets and bus and train stations to connect further afield if needed.

ACCOMMODATION COMPRISES

Front door to:-

ENTRANCE HALL

Staircase rising to:-

LANDING

Double glazed window to front gaining sea views. Radiator. Wall mounted consumer unit. Door to:-

INNER HALL

Doors to:-

BATHROOM

Fitted with a white suite comprising panelled bath, low level WC and pedestal wash handbasin. Obscure double glazed window to front. Radiator.

BEDROOM TWO 13' 2" x 7' 10" (4.01m x 2.39m)

Double glazed window to side. Radiator.

KITCHEN/LOUNGE/DINER 13' 2" x 11' 6" (4.01m x 3.50m) plus recesses LIVING SPACE

A lovely light and airy space with double glazed window to side gaining sea glimpses. Laminate flooring. Radiator.

KITCHEN

Fitted with a matching range of light wood effect wall and base cupboards with roll edge worksurfaces over. Space and plumbing for washing machine. Space for cooker. Stainless steel single drainer sink unit. Double glazed window to side.

From living space, door to:-

BEDROOM ONE 13' 2" x 9' 7" (4.01m x 2.92m) maximum measurements

Double glazed window to side. Radiator.

OUTSIDE

To the front of the property there is a generous lawned garden enclosed by picket fencing. There is also a grassed area to the side of the apartment.

LEASEHOLD INFORMATION

The property is being sold with a new 999 year lease. The service charge is estimated to be £33 per calendar month to include buildings insurance.

SERVICES

Mains water, mains electricity, mains drainage.

AGENT'S NOTES

The Council Tax band for the property is band 'A'. We understand a condition of the lease is that the property cannot be used for holiday letting.

DIRECTIONS

From Penzance promenade proceed westerly to Newlyn. Go past Jelbert's ice cream shop on your right and then take the second turning right on to Chywoone Hill. Continue to the top of the hill and turn left on to Chywoone Avenue. At the roundabout, take the first turning where to property will be found on the left hand side. If using What3words:- absorb.hush.enabling

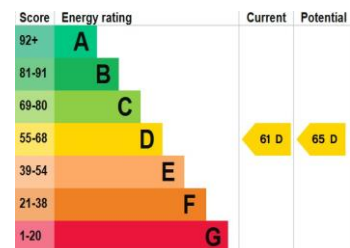
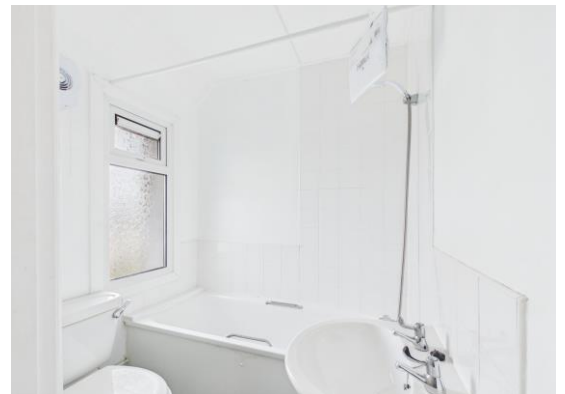



MAP's top reasons to view this home

- Self-contained two first apartment
- Open plan kitchen/lounge/dining space
- Gas central heating and double glazing
- Sea views
- Offered for sale chain free
- New 999 year lease

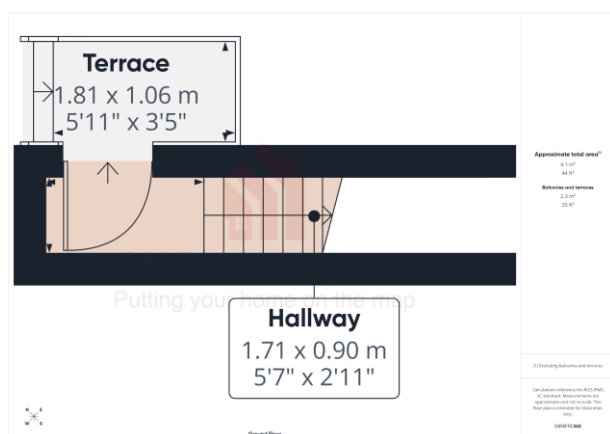
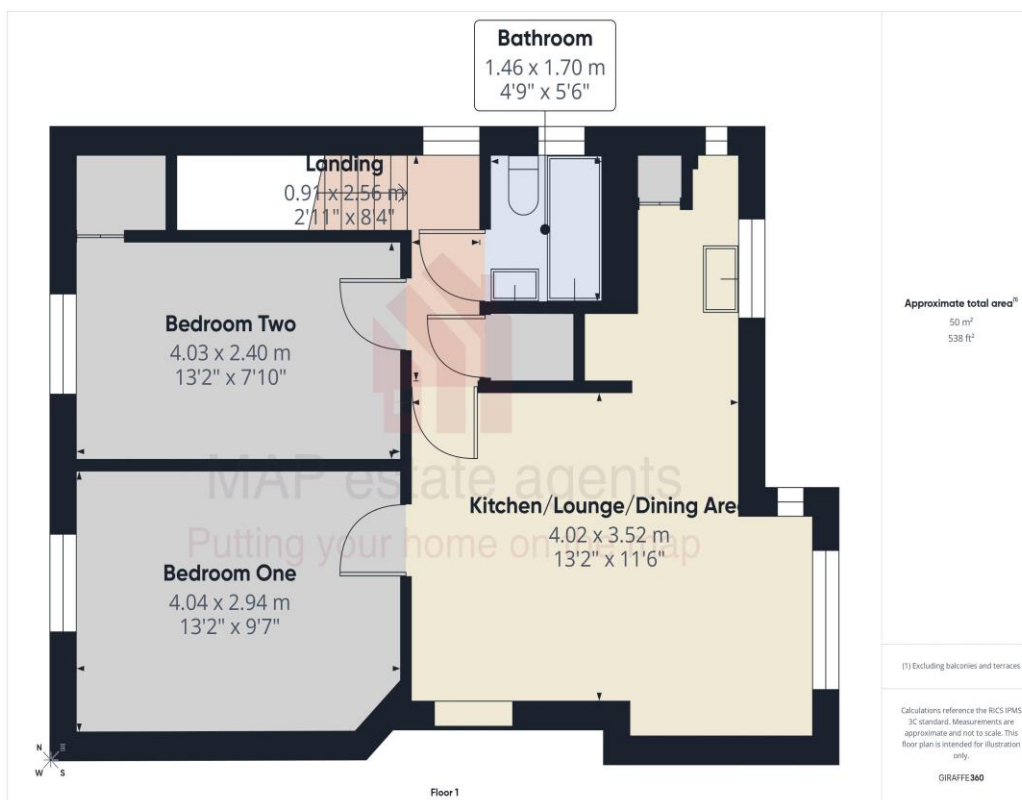

sales@mapestategents.com

Gateway Business Park, Barncoose
Cornwall TR15 3RQ

www.mapestategents.com

01209 243333 (Redruth & Camborne)
01736 322200 (St Ives & Hayle)
01326 702400 (Helston & Lizard Peninsula)

01736 322400 (Penzance & surrounds)
01326 702333 (Falmouth & Penryn)
01872 672250 (Truro)

IMPORTANT: Map estate agents for themselves and for the vendors or lessors of this property whose agents they are give notice that the particulars are produced in good faith and are set out as a general guide only and do not constitute any part of a contract and no person in the employment of Map estate agents has any authority to make or give any representation or warranty in relation to this property.