

Crockers Cottage  
Upper Woodford





## A four bedroom cottage with river views, set in a popular village location to the north of Salisbury

Crockers Cottage,

Upper Woodford, Salisbury, SP4 6NU

Guide Price:

£729,950



2



4



0



2

- Charming period cottage
- Unlisted property
- Open plan kitchen/dining room
- Sitting room
- Four bedrooms
- Generous gardens (approx 0.8 acres)
- Outstanding location
- Breathtaking rural views
- Child friendly layout
- Excellent connectivity and lifestyle opportunities

## The Property

Originally a smaller cottage dating from the late 1800s, Crockers Cottage is an unlisted home that was thoughtfully extended in 2004 and meticulously renovated by the current owners, who have lived here since 1996. Parking is available along the village lane, from where a side gate provides access to the front door of the cottage.

The front door opens into a light and bright open-plan kitchen/dining room, enhanced by new hardwood windows and doors installed in 2023. The kitchen is fitted with a Rangemaster oven and hob, complemented by bespoke, hand-built hardwood shaker-style wall and base units with granite worktops. A large, matching free-standing dresser is included in the sale and a slate tiled floor which runs through to a useful utility room with plumbing for a washing machine and tumble dryer, and housing the oil-fired boiler.

The sitting room with solid oak flooring enjoys an east-facing aspect and features an exposed brick wall, a log-burner, and lovely views over the river and the water meadow beyond.

Upstairs, the accommodation comprises four bedrooms, including one ensuite, together with a family bathroom. The principal bedroom benefits from an ensuite shower room, a vaulted ceiling and French doors opening onto a west-facing terrace. Bedroom two enjoys beautiful views and features a charming original fireplace. Bedroom three has been extended and incorporates an additional study area, with potential for use as a further reception room if desired. Bedroom four is situated adjacent to the family bathroom.

Crockers Cottage offers a rare combination of character, thoughtful modernisation and an exceptional setting. With its generous accommodation, carefully landscaped gardens and breathtaking views across the river and water meadows, the property is ideally suited to both family life and relaxed entertaining. Set within the heart of the village yet enjoying a wonderfully private and peaceful position, this is a home that truly embraces its surroundings and offers a special lifestyle opportunity.

**Services** - Ofcom suggests that all major mobile networks offer good coverage and Ultrafast broadband is available,

Mains electricity, water and drainage, Sewerage-treatment plant

## Tenure

Freehold

## EPC Rating

D (55)

## Outgoings

Council Tax Band: D

## Size

1384 sqft





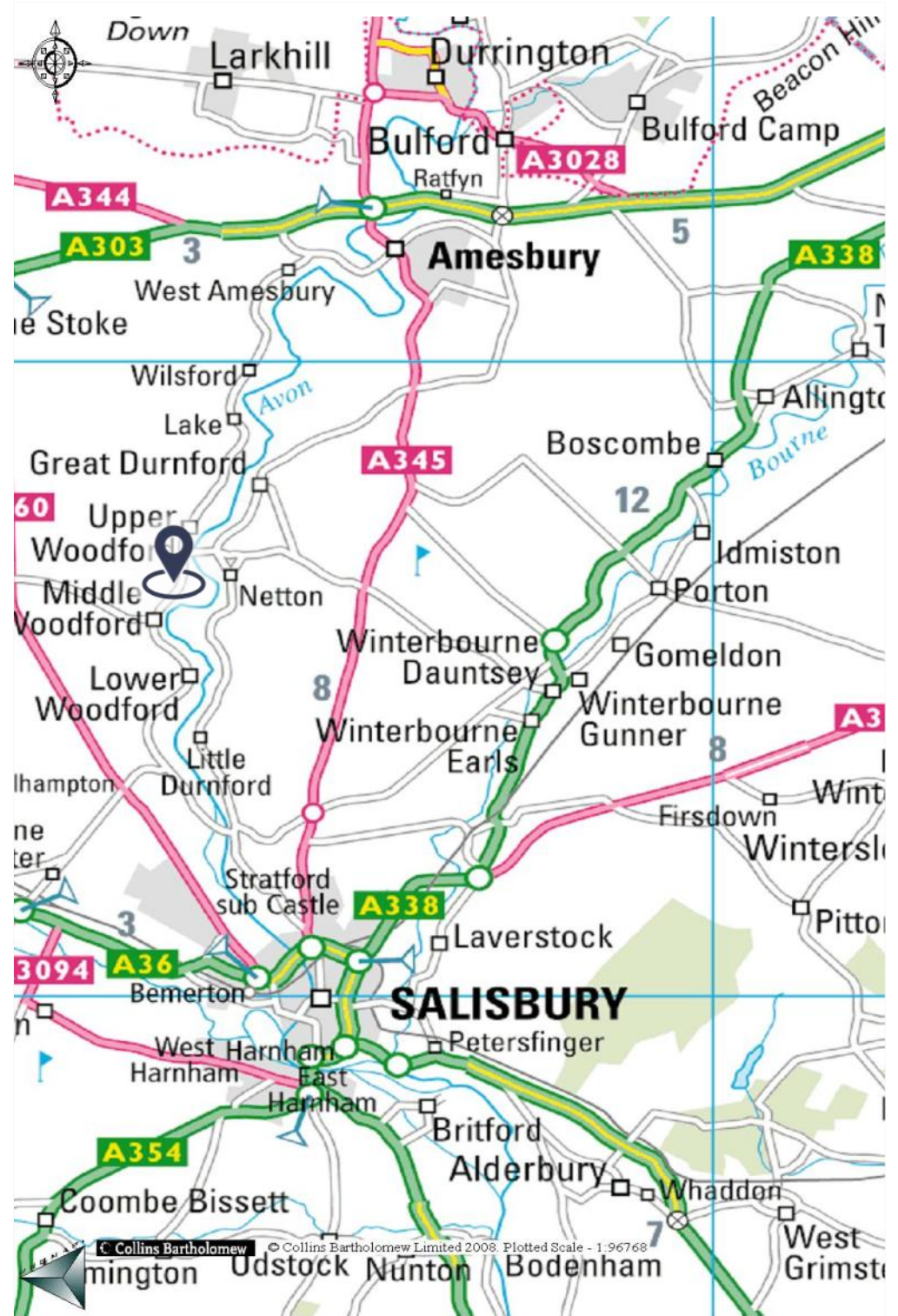





## Outside

In total, the property extends to approximately 0.38 acre, with gardens to the rear enjoying exceptional, far-reaching views across the river and water meadows beyond, providing a wonderfully peaceful backdrop to the house. Steps lead up from the side of the house to the elevated rear garden.

The owners have lived here with young children and have thoughtfully created safe, level areas of garden for play, while still retaining a sense of space and informality. Carefully terraced lawns maximise usable areas for everyday family life, complemented by a further BBQ patio for entertaining, a large garden shed, and a wild area ideal for bonfires, composting, and enjoying the natural setting.

## Location

The Woodford Valley is officially recognised as an Area of Outstanding Natural Beauty and are part of the National Cycle Network and is widely regarded as one of the most picturesque stretches of the River Avon, running between the A303 at West Amesbury and the historic cathedral city of Salisbury. The river meanders gently south through unspoilt countryside, creating a landscape of open water meadows, rolling fields and quiet lanes that is ideal for those seeking a rural lifestyle with a strong sense of place.

Upper Woodford lies just a few miles north of Salisbury, offering easy access to the city's excellent range of shopping, cultural and leisure facilities, while retaining the charm and tranquillity of village life. The area is well served by a number of highly regarded schools in both the state and private sectors.

The surrounding countryside provides outstanding opportunities for walking and cycling directly from the village, with further outdoor pursuits including fly fishing, shooting and horse riding available locally through established clubs and stables. Despite its peaceful setting, the area remains well connected, with the A303 at Amesbury linking to the M3 motorway, and mainline rail services from Salisbury and Grateley offering frequent journeys to London Waterloo.





Approximate Floor Area = 128.6 sq m / 1384 sq ft (Excluding Shed)

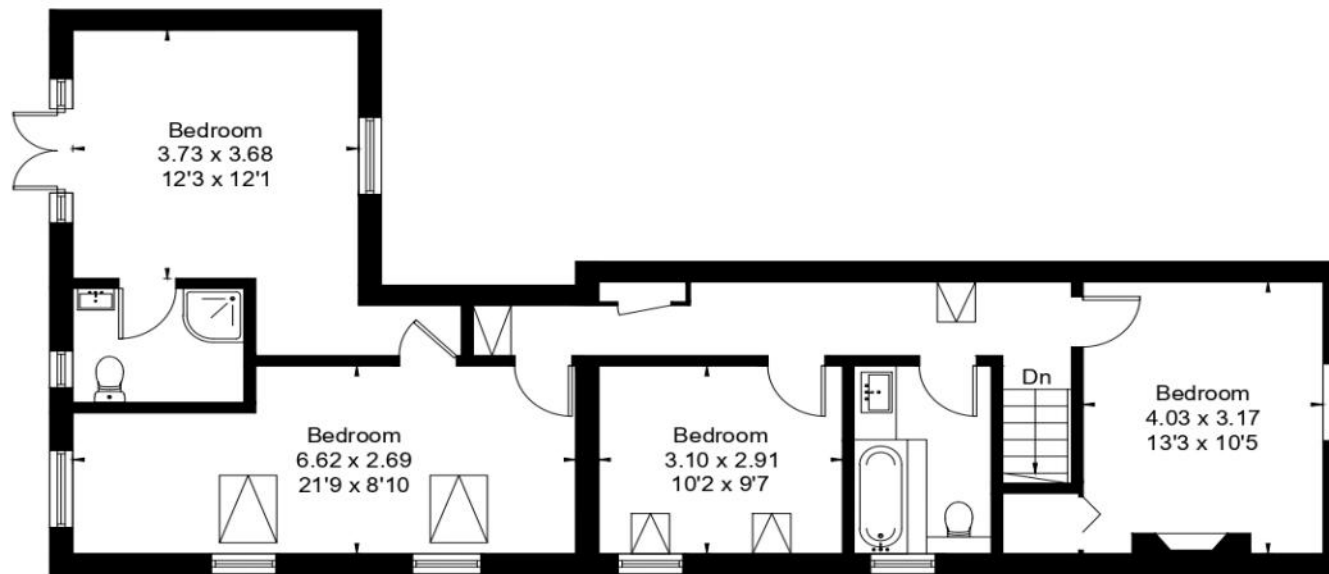

First Floor



Ground Floor

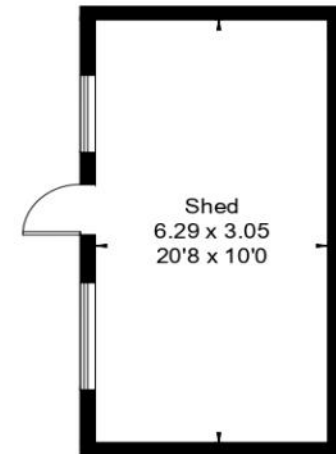

(Not Shown In Actual Location / Orientation)



This floor plan has been drawn in accordance with RICS Property Measurement 2nd edition.

All measurements, including the floor area, are approximate and for illustrative purposes only. @fourwalls-group.com #102117

### Disclaimer Notice

Myddelton & Major LLP and their clients give notice that: - i) they have no authority to make or give any representations or warranties in relation to the property, ii) these particulars do not form part of any offer or contract and must not be relied upon as statements or representations of fact, iii) any areas, measurements or distances are approximate. The text, photographs and plans are for guidance only and are not necessarily comprehensive. It should not be assumed that the property has all the necessary planning, Building Regulation or other consents, and, any services, equipment or facilities have not been tested by the agent. iv) the purchaser must satisfy themselves by inspection or otherwise.



Myddelton  
& Major™

Call. 01722 337 575

Email. [residential@myddeltonmajor.co.uk](mailto:residential@myddeltonmajor.co.uk)

Click. [myddeltonmajor.co.uk](http://myddeltonmajor.co.uk)

Visit. 49 High Street, Salisbury, Wiltshire, SP1 2PD

