

Garage / Workshop at Upton Manor Court, St. Marys Road, Brixham, TQ5 9QQ

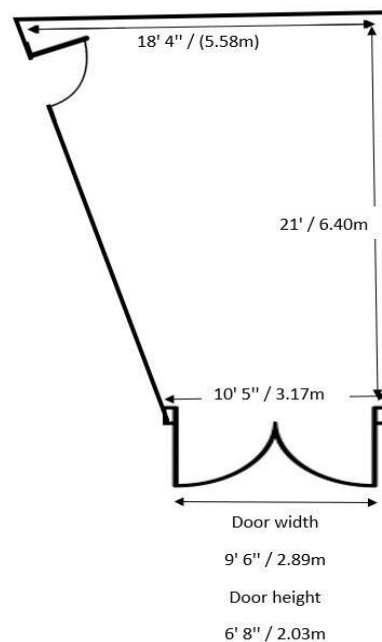

A rare opportunity to purchase a spacious freehold **LOCK UP GARAGE / WORKSHOP** located to the rear of Upton Manor Court. This garage has its own electric supply and meter providing power and lighting.

Perfect for storage or hobby workshop use.

Double opening doors to front, Mezzanine storage area to rear.

Pedestrian door at rear to small external courtyard area.

Internal dimensions are shown on the floor plan.

Please note internal height is 9'7" / 2.92m at the lower end of the pitch.

Viewing by appointment only.

£49,950 Freehold