



📍 23 Broad Street, Beechingstoke, Pewsey, Wiltshire, SN9 6HP

🔗 Auction Guide £150,000

- For Sale by Online Auction
- Thursday 9th July 2026
- Lot 23
- Guide Price £150,000+

🏠 Freehold

📊 EPC Rating E



LOT 23
FOR SALE BY ONLINE AUCTION
THURSDAY 9th JULY 2026
GUIDE PRICE £150,000+

2 Bedroom timber framed detached chalet bungalow situated in the popular village of Beechingstoke and in need of modernisation. Potential to extend/redevelop (subject to consents).

The accommodation comprises on the ground floor; entrance hall, living room, dining room, kitchen, utility, rear hallway, shower room and bedroom. On the first floor; large dual aspect bedroom. The property has double glazing and oil fired central heating.

The front garden is laid mainly to gravel with flower bed borders. Large tarmacadam driveway for several cars leading to timber garage/workshop. The rear garden is mainly laid to gravel and paving slabs and overlooking farmland.

what3words///heaven.stay.prepare

For further information please go to our auction site.

Situation

The property is situated within the village of Beechingstoke, a small rural area located in the Vale of Pewsey. The village is approximately 2 miles south of Pewsey where a wider range of amenities can be found including shops, cafe's, public houses, schools, healthcare facilities and a mainline railway station providing direct services to London Paddington and the South West. The nearby market towns of Marlborough and Devizes offer further shopping and leisure opportunities.

Viewings

To arrange a viewing, contact: Pewsey Office

There will be numerous pre-arranged open house viewing slots lasting for 30 minutes and you can book in by contacting the Auctioneers.

If you have any concerns with viewings, please contact the relevant Strakers office and we would be happy to discuss them with you and hopefully put you at ease.

Online Auction

In order to bid at Strakers Online Auctions, you will first need to create an account by providing your contact details. You will be asked to read and accept our Online Auction Terms and Conditions. In order to bid online, you will be required to register a credit or debit card for the bidder security deposit. Strakers are required by law to carry out an online anti-money laundering check on all persons wishing to bid. In general terms, you are strongly advised to view the property and take professional advice as to its condition and suitability.

When the auction opens at 8am the day of the auction, you will be able to place bids in line with the pre-determined bid increment levels, using the bid increase (+) and decrease (-) buttons provided. It is recommended you check your web browser will allow you to bid in good time as some browsers' security can block the ability to bid. We recommend using Google Chrome when possible.

We offer property for sale by immediate, unconditional contract. This means that the fall of the electronic gavel constitutes an exchange of contracts between the buyer and seller. Both parties are legally bound to complete the transaction usually within 20 working days following the close of the auction but this will be confirmed within the legal documentation.



Ground Floor

Approx. 80.7 sq. metres (869.0 sq. feet)

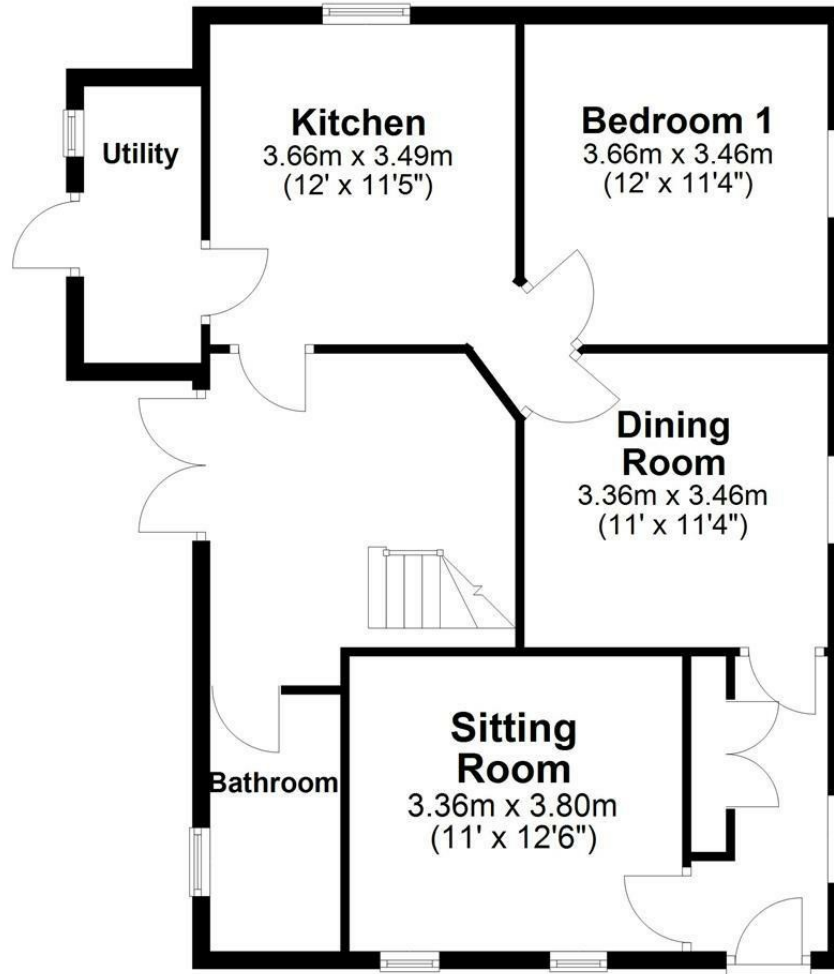

First Floor

Approx. 34.6 sq. metres (372.6 sq. feet)

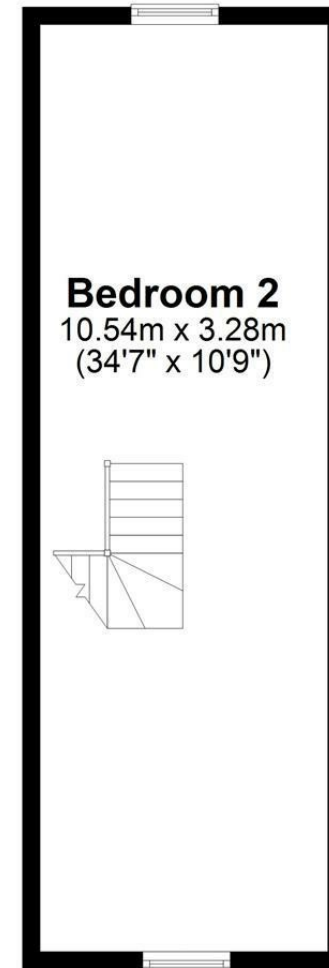

Total area: approx. 115.3 sq. metres (1241.6 sq. feet)

Disclaimer These particulars, whilst believed to be accurate are set out as a general outline only for guidance and do not constitute any part of an offer or contract. Intending purchasers should not rely on them as statements of representation of fact, but must satisfy themselves by inspection or otherwise as to their accuracy. No person in this firm's employment has the authority to make or give any representation or warranty in respect of the property. All measurements and distances are approximate only. Your home is at risk if you do not keep up repayments on a mortgage or other loan secured on it.