



P R I M E R E S I D E N T I A L

P R E S E N T S

North End, Buckhurst Hill



elliott E | J james

01454 888888

North End, Buckhurst Hill



Guide Price £600,000 - £625,000 Situated within a desirable residential setting in Buckhurst Hill, this exceptional brand-new end of terrace home offers beautifully appointed accommodation, contemporary styling and outstanding energy efficiency, making it an ideal purchase for first-time buyers, professionals, downsizers and investors alike.

Constructed in 2026 using traditional brick-built construction, the property has been finished to an impressive specification throughout and benefits from a superb EPC rating of 95 (A), helping to reduce running costs while providing a comfortable and sustainable living environment.

The ground floor features a bright and spacious open-plan living area, seamlessly connecting to a stylish contemporary kitchen fitted with integrated appliances and ample storage. French doors lead directly onto a private decked rear garden, creating the perfect space for outdoor dining, entertaining or simply relaxing. A beautifully finished family bathroom is also conveniently located on the ground floor.

Upstairs, the property offers two well-proportioned double bedrooms, both flooded with natural light and finished in a neutral palette ready for immediate occupation.

Externally, the home enjoys the benefit of a private decked rear garden and a driving way, a valuable feature in this sought-after location.

For additional peace of mind, the property is offered with a 10 year new build warranty, providing reassurance for years to come.

Please Note: Some marketing images have been digitally enhanced using artificial intelligence (AI) technology for illustrative purposes. The property is currently vacant and all interested parties are advised to inspect the property in person to satisfy themselves as to its condition, layout and specification.



The property market has always interested me and seeing the reaction when someone finds their next home is something that really drives me to go above and beyond. I have a pride in my local area having grown up here, this also allowed me to grow a strong knowledge of the local community. With experience in the role already I look to provide a service to both buyers and sellers in which communication and transparency are key. I am incredibly proud to be a part of such a brilliant team dedicated to providing bespoke service to such a beautiful community.



An unrestricted fully immersive walkthrough is available in our E|J Business Lounge by arrangement. Restricted walkthrough access is available on our website through your smartphone or desktop.

Daniel Thomas
contact@ejpr.co.uk
0208 0165 333

N
E
E
D

T
O

K
N
O
W

| | | |
|----------------------|-----------------------------|-------------------|
| Sqft 634.00 sq ft | Type House - End Terrace | Style New Home |
| Bedrooms 2 | Receptions 1 | Bathrooms 1 |
| Tenure Freehold | Local Authority Epping | Tax Band D |

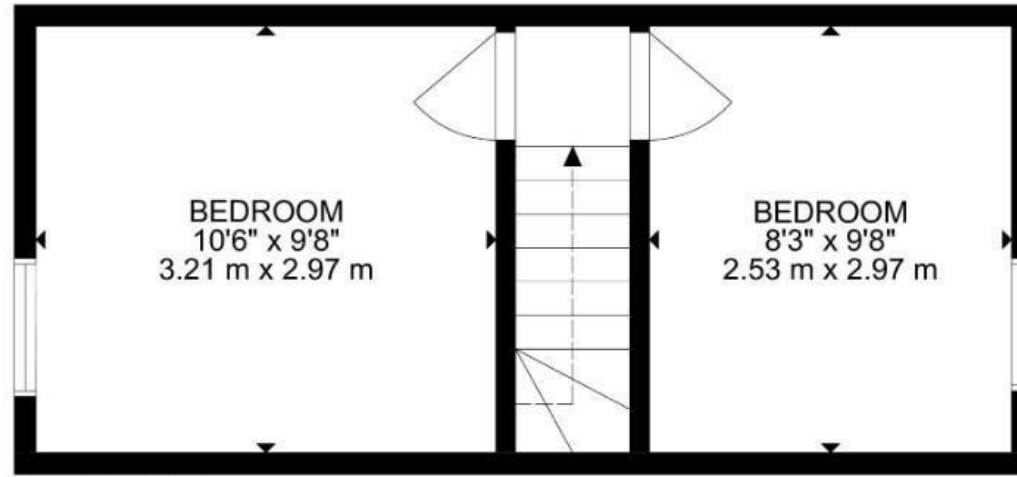

FIRST FLOOR

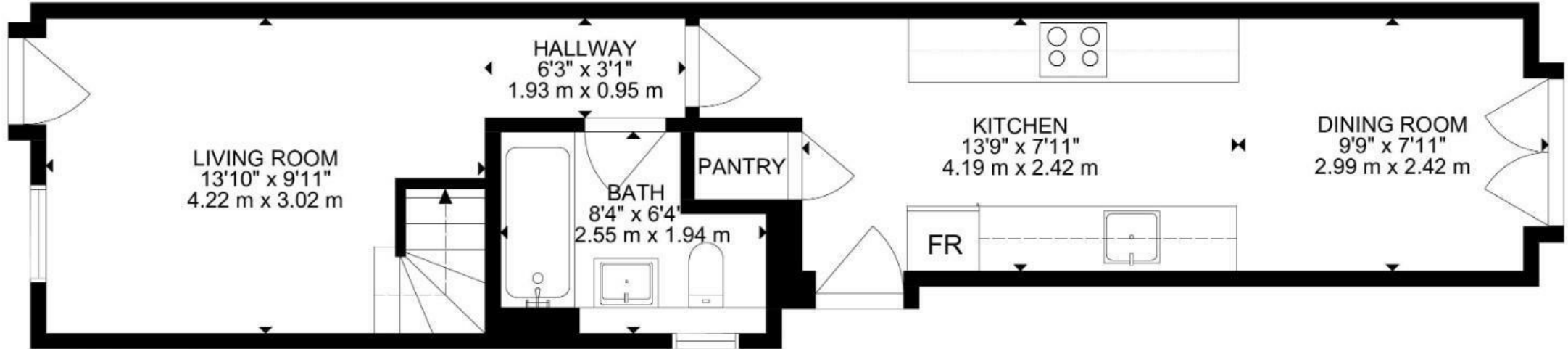

GROUND FLOOR

GROSS INTERNAL AREA

GROUND FLOOR: 419 SQ FT, 39 m², FIRST FLOOR: 215 SQ FT, 20 m²

TOTAL: 634 SQ FT, 59 m²

SIZE AND DIMENSIONS ARE APPROXIMATE, ACTUAL MAY VARY

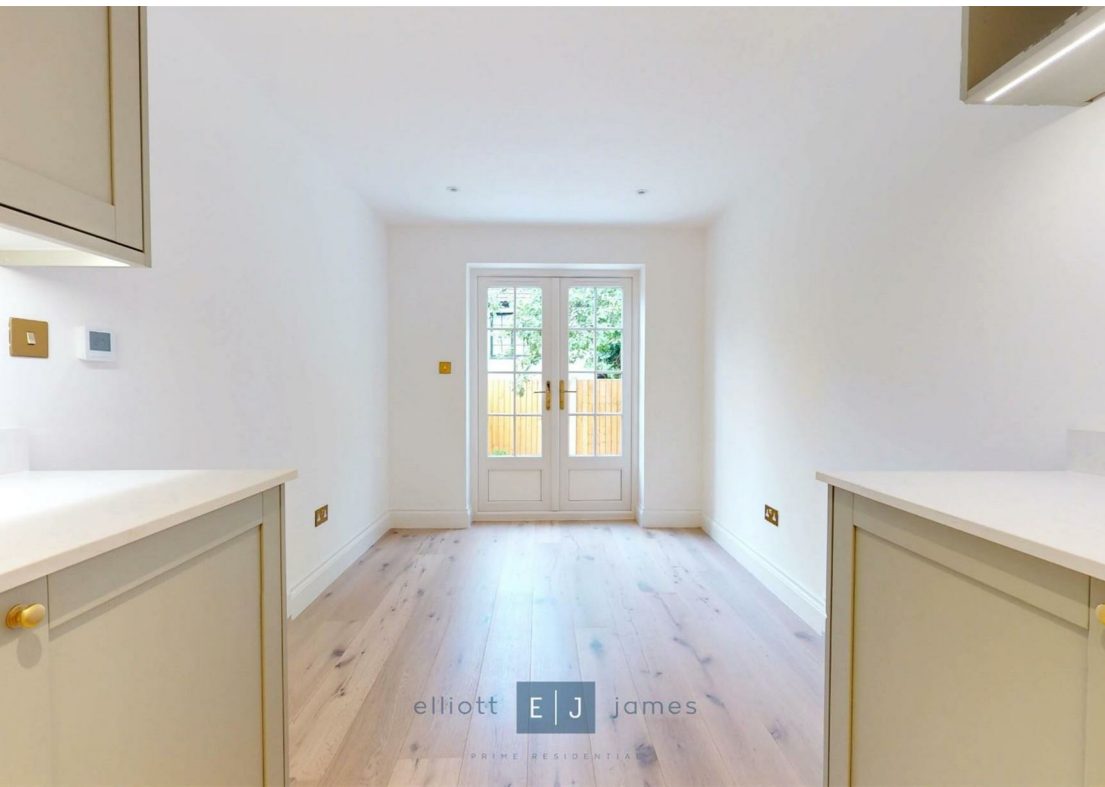

MAP & EPC

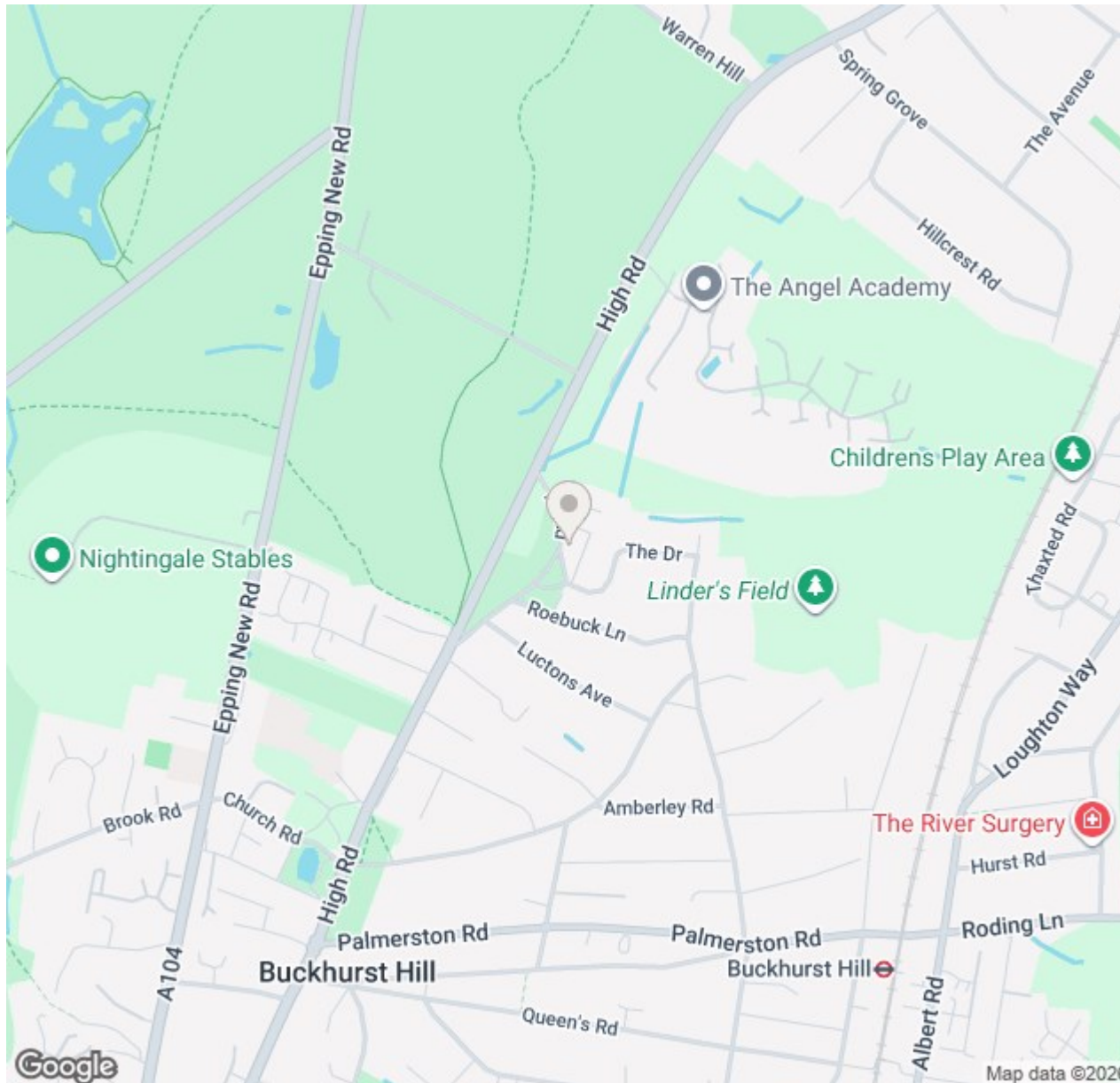

| Energy Efficiency Rating | Current | Potential |
|---|-------------------------|-----------|
| Very energy efficient - lower running costs | | |
| (92 plus) A | | |
| (81-91) B | | |
| (69-80) C | | |
| (55-68) D | | |
| (39-54) E | | |
| (21-38) F | | |
| (1-20) G | | |
| Not energy efficient - higher running costs | | |
| | 95 | 96 |
| England & Wales | EU Directive 2002/91/EC | |

| Environmental Impact (CO ₂) Rating | Current | Potential |
|---|-------------------------|-----------|
| Very environmentally friendly - lower CO ₂ emissions | | |
| (92 plus) A | | |
| (81-91) B | | |
| (69-80) C | | |
| (55-68) D | | |
| (39-54) E | | |
| (21-38) F | | |
| (1-20) G | | |
| Not environmentally friendly - higher CO ₂ emissions | | |
| | | |
| England & Wales | EU Directive 2002/91/EC | |

elliott  james

165 | High Road | Loughton | IG10 4LF

Contact Us : 0208 0165 333 | contact@ejpr.co.uk

Follow us on social media | Search 'ejpr165'



These particulars have been prepared with approximate measurements in good faith by Elliott James – Prime Residential with the assistance of the vendor. The intention is to provide a fair and accurate guide to the property. These details do not constitute or form any part of an offer or contract. All interested parties must verify for themselves the accuracy of the information provided. The structural condition of the property or the condition of the heating, plumbing or electrical installations or any appliances have not been checked or tested and suitable investigations by interested parties should be conducted prior to purchase.