



Severn Villa Haw Bridge
Tirley GL19 4HJ



STEVE GOOCH
ESTATE AGENTS | EST 1985

Severn Villa Haw Bridge

Guide Price £700,000

Tirley GL19 4HJ

A THREE BEDROOM DETACHED BRICK BUILT COTTAGE with AMPLE CHARACTER and CHARM with BARN, STABLING, SUMMER HOUSE, GARDENS AND GROUNDS OF APPROXIMATELY 7.62 ACRES, SITUATED IN A BEAUTIFUL COUNTRYSIDE LOCATION ENJOYING FAR REACHING VIEWS.

Tirley has its own local Church and public house.

There is a Post Office available in neighbouring Ashleworth.

The nearest towns are Tewkesbury ((7 miles), Cheltenham (10 miles) and Gloucester (11 miles) for more comprehensive shopping and recreational facilities with the Malvern Hills to the North and Cotswold Hills to the East.

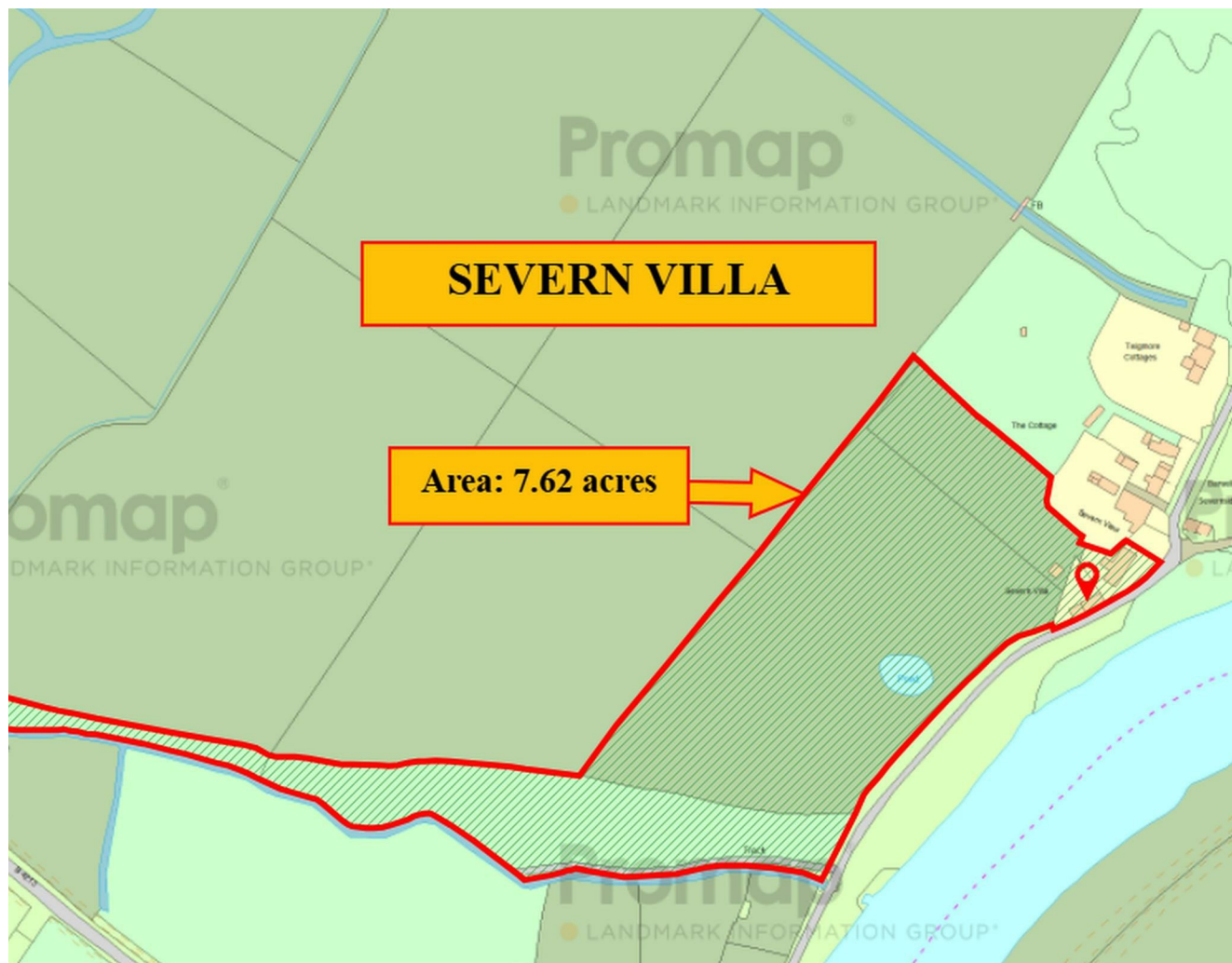

Enter the property via side aspect double glazed front door into:

KITCHEN / BREAKFAST ROOM

19'10 x 12'6 (6.05m x 3.81m)

Recently refitted to comprise of a range of base and wall mounted units with oak worktops and tiled splashbacks, space for American fridge / freezer, plumbing for dishwasher, Belfast sink unit with mixer tap, space for a range oven, extractor fan, tiled flooring, breakfast bar area, feature fireplace, radiator, inset spotlighting, front, side and rear aspect windows. Glazed door to:

LOUNGE

24'0 x 12'1 (7.32m x 3.68m)

Brick fireplace with wooden mantle over housing cast iron log burner, tiled floor throughout, panelled radiators, exposed beamwork, two front aspect windows. Glazed wooden door into:

SUN ROOM

16'7 x 13'1 (5.05m x 3.99m)

Vaulted ceiling with exposed beamwork, tiled flooring, radiators, front, side and rear aspect windows, double opening French doors to large patio area. Door from kitchen to:

INNER HALLWAY

Vaulted ceiling, Open Reach point, under stairs storage cupboard, radiator, stairs leading off, two rear aspect windows. Thumb latch door into:

UTILITY ROOM

11'9 x 6'0 (3.58m x 1.83m)

Restricted head room (just under 6'0), plumbing for washing machine, space for tumble dryer, base unit with oak worktops and tiled splashbacks, Belfast sink unit with cupboard below, tiled flooring, WC, exposed beam, side aspect window. Door to:

REAR RECEPTION / UTILITY / DOG GROOMING ROOM

11'4 x 10'11 (3.45m x 3.33m)

Tiled flooring, oak framed canopy porch, side and rear aspect windows, back door.

FROM THE INNER HALLWAY, A TURNING STAIRCASE LEADS TO THE FIRST FLOOR.

LANDING

Single radiator.





BEDROOM 1

12'10 x 12'8 (3.91m x 3.86m)

Built-in wardrobes, front aspect window.

BEDROOM 2

12'11 x 11'8 (3.94m x 3.56m)

Single radiator, front aspect window.

BEDROOM 3

12'10 x 9'10 (3.91m x 3.00m)

Exposed wooden floorboards, access to roof space, front aspect window.

BATHROOM

11'5 x 6'3 (3.48m x 1.91m)

Modern suite comprising panelled bath with mixer tap and shower detachment, double shower cubicle accessed via sliding screen with inset overhead and detachable shower system, WC, vanity wash hand basin with cupboard below, chrome heated towel rail, laminate floor, tiled splashbacks, extractor fan, spotlighting, rear aspect window.

OUTSIDE

There are two vehicular gated accesses, the second which has double opening wooden gates leading to a gravelled parking area for four / five vehicles, flood defense wall and gated access into the front gardens which are laid to lawn, oil tank, access via both sides of the cottage to the rear. The flood wall continues around all four sides of the property and the enclosed gardens comprise of a decked area, large patio seating area, various outside power points, outside lighting and water taps.

The first gated access has double opening electric gates which lead to a parking and turning area for four vehicles. This leads to:

DETACHED BRICK BUILT BARN

35'6 x 15'4 (10.82m x 4.67m)

Accessed via stable door with three x 12' 12' stable units, vaulted ceiling, power and lighting, water supply, front aspect window.

GARAGE

17'8 x 12'11 (5.38m x 3.94m)

With commensurate room over.

Gated access leads into:

PADDOCK ONE

Currently an extension of the formal garden which has steps leading to:

GARDEN SUMMER HOUSE / STUDIO

16'5 x 13'3 (5.00m x 4.04m)

Covered veranda area, front and side aspect windows. Double doors leading into fitted kitchen, power and lighting, enjoying beautiful views towards The Malverns.

Gate leads to:

MAIN PADDOCK

Alternatively accessed via a five bar gate from the lane, all enclosed by post and rail fencing. Beyond the paddock, gated access leads to:

ORCHARD AREA

With gated access from both ends.

The gardens and grounds extend to approximately 7.62 acres.

AGENT'S NOTE

The property has flooded most recently in 2024. The property benefits from having a flood wall, sump pumps installed to pump out excess water, back up generator if electricity fails, an alarm system in place to alert if back up generator is required. All measures have been taken to protect the house from flooding with flood doors and flood gates fitted on the outside of the doors.

SERVICES

Mains water and electric, septic tank, oil-fired heating.

MOBILE PHONE COVERAGE / BROADBAND AVAILABILITY

It is down to each individual purchaser to make their own enquiries.

WATER RATES

Severn Trent - to be confirmed.

LOCAL AUTHORITY

Council Tax Band: F
Tewkesbury Borough Council, Council Offices, Gloucester Road,
Tewkesbury, Gloucestershire. GL20 5TT.

TENURE

Freehold.





VIEWING

Strictly through the Owners Selling Agent, Steve Gooch, who will be delighted to escort interested applicants to view if required. Office Opening Hours 8.30am - 7.00pm Monday to Friday, 9.00am - 5.30pm Saturday.

DIRECTIONS

From Newent, proceed along the B4221 towards Dymock taking the first turning right onto the Tewkesbury Road towards Staunton. Proceed along this road for 4 / 5 miles until reaching the junction with the A417. At the A417 proceed straight over until you come to a T junction, turn left towards Tewkesbury and continue along this road for 1 - 2 miles until you see a right hand turning signposted for Tirley. Carry on down the hill along that road and upon reaching the Haw Bridge, turn left at the old Riverside Inn, carrying down the little lane, where the property can be located on the left hand side as marked by our 'For Sale' board. And marked at the top of the lane by an arrow board.

PROPERTY SURVEYS

Qualified Chartered Surveyors (with over 20 years experience) available to undertake surveys (to include Mortgage Surveys/RICS Housebuyers Reports/Full Structural Surveys).

AWAITING VENDOR APPROVAL

These details are yet to be approved by the vendor. Please contact the office for verified details.

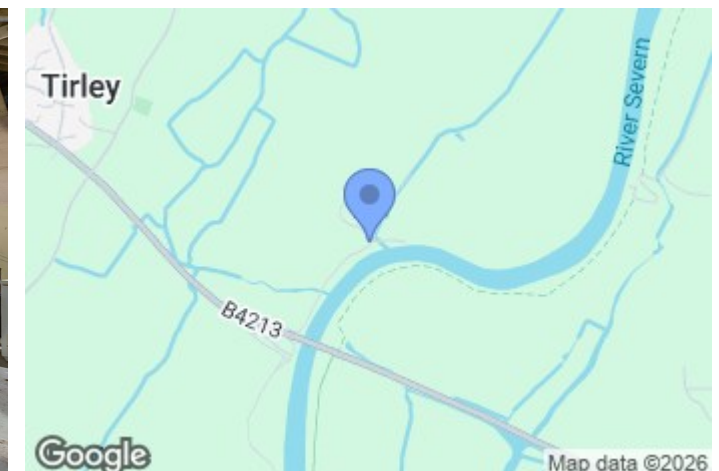

Haw Bridge, Tirley, Gloucester, GL19

Approximate Area = 1724 sq ft / 160.1 sq m
 Outbuilding = 1248 sq ft / 115.9 sq m
 Total = 2972 sq ft / 276. sq m
 For identification only - Not to scale

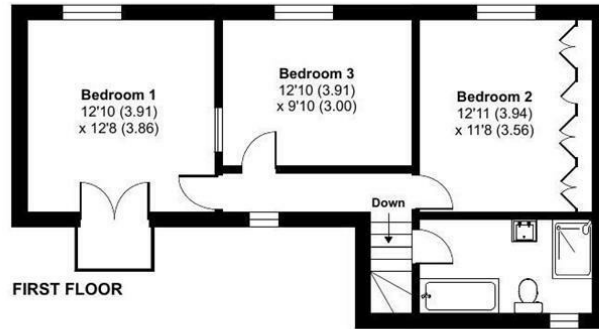

FIRST FLOOR

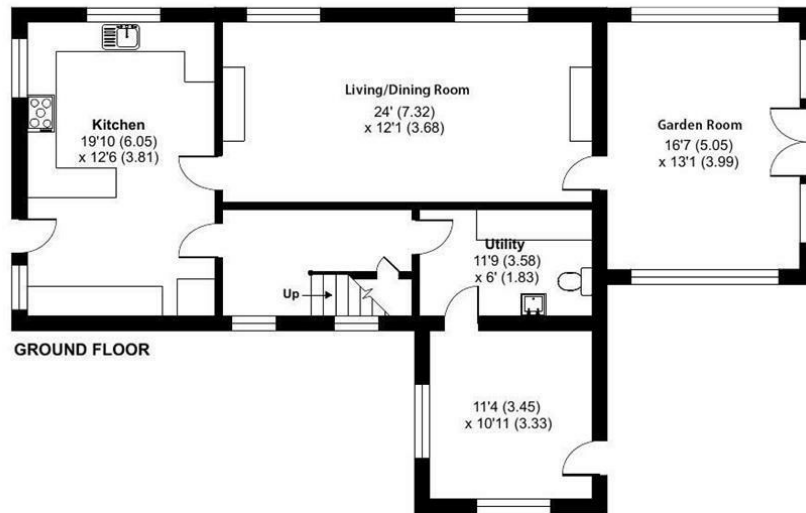

GROUND FLOOR

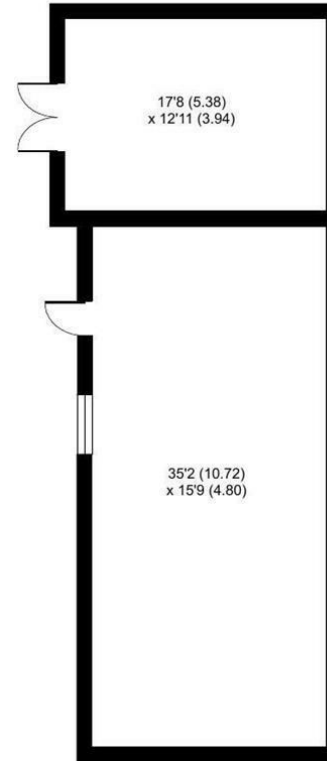

OUTBUILDING 1 GROUND FLOOR

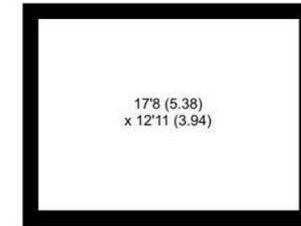

OUTBUILDING 1 FIRST FLOOR

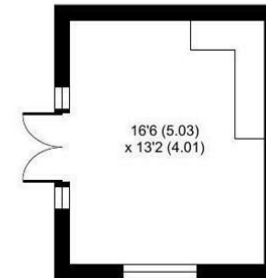

OUTBUILDING 2

Floor plan produced in accordance with RICS Property Measurement 2nd Edition, Incorporating International Property Measurement Standards (IPMS2 Residential). © nchecom 2025. Produced for Andrew Grant. REF: 1336496

MISREPRESENTATION DISCLAIMER

All reasonable steps have been taken with the preparation of these particulars but complete accuracy cannot be guaranteed. If there is any point which is of particular importance to you, please obtain professional confirmation. Alternatively, where possible we will be pleased to check the information for you. These particulars do not constitute a contract or part of a contract. All measurements quoted are approximate. The fixtures, fittings and appliances have not been tested and therefore no guarantee can be given that they are in working order. Any drawings, sketches or plans are provided for illustrative purposes only and are not to scale. All photographs are reproduced for general information and it cannot be inferred that any items shown are included in the sale.

Energy Efficiency Rating		Environmental Impact (CO ₂) Rating	
	Current	Potential	
Very energy efficient - lower running costs			Very environmentally friendly - lower CO ₂ emissions
(92 plus) A			(82 plus) A
(81-91) B			(69-80) B
(69-80) C			(55-68) C
(55-68) D			(39-54) D
(39-54) E			(21-38) E
(21-38) F			(1-20) F
(1-20) G			Not environmentally friendly - higher CO ₂ emissions
Not energy efficient - higher running costs			
England & Wales	EU Directive 2002/91/EC	59	England & Wales
		41	EU Directive 2002/91/EC





4 High Street, Newent, Gloucestershire. GL18 1AN | (01531) 820844 | newent@stevegooch.co.uk | www.stevegooch.co.uk

Residential Sales | Residential Lettings | Auctions | Surveys