



The
LEE, SHAW
Partnership

Vine Cottage
Third Road, Wildmoor, Bromsgrove B61 0BT



DETACHED COUNTRY RESIDENCE

An Exceptional Country Home
with Annexe, Equestrian
Facilities & 1.3 Acres

Vine Cottage is a beautifully presented detached country residence, offering approximately 3,200 sq ft of versatile accommodation set within attractive gardens and grounds extending to around 1.3 acres.

Originally two Victorian nailers' cottages, the property has been sympathetically renovated and thoughtfully extended to create a superb blend of period charm and contemporary living. Character features including exposed beams, vaulted ceilings and wood-burning stoves combine effortlessly with stylish modern additions and high-quality finishes throughout.

This outstanding lifestyle property provides spacious family accommodation together with excellent entertaining space, a self-contained annexe, home gym, double garage and equestrian facilities including stabling and paddock land.

VERSATILE FAMILY LIVING

The property is approached via an electrically gated driveway leading to an extensive rear courtyard providing generous parking and turning space.

A canopy porch opens into the impressive dining hall, featuring wooden flooring, exposed ceiling beams, staircase rising to the first floor and bi-fold doors opening onto the south-facing rear gardens.

The superb triple-aspect sitting room enjoys a wealth of character, with exposed beams, wooden flooring and a striking brick fireplace housing a wood-burning stove, creating a warm and inviting family living space.

An inner hallway leads through to the magnificent breakfast kitchen — undoubtedly the heart of the home. Designed with both family living and entertaining in mind, the room features a vaulted ceiling with four Velux roof windows and bi-fold doors flooding the space with natural light. The bespoke kitchen, understood to have been crafted by Ironbridge Interiors, incorporates extensive cabinetry with pull-out storage, granite work surfaces, sink with boiling water tap and electric Aga.





FLEXIBLE LIVING

The current owners have further enhanced the ground floor accommodation with the addition of a stylish entertainment room complete with fitted bar, part-vaulted ceiling and adjoining guest cloakroom/shower room.

Self-Contained Annexe

The annexe provides valuable additional accommodation with exceptional flexibility for a variety of uses including guest accommodation, multi-generational living, home working or potential income generation.

The space includes open-plan living/sleeping accommodation with log burner, kitchenette with oven and double sink, electric underfloor heating, ensuite shower room and access to generous loft storage via a pull-down ladder.





**WE DON'T SELL HOUSES,
WE SELL HOMES.**



BEAUTIFUL SURROUNDINGS

Location

Wildmoor is a highly regarded semi-rural location situated just north of Bromsgrove, offering excellent access to the Midlands motorway network including Junction 4 of the M5 and Junction 1 of the M42, making it ideal for commuting to Birmingham and beyond.

The nearby village of Catshill provides local amenities and schooling, whilst the popular villages of Belbroughton and Hagley are also within easy reach. Worcester and the wider West Midlands conurbation are readily accessible.

Additional Information

Tenure: Freehold

Construction: Conventional masonry construction with pitched tiled roofs

Services: Mains water and electricity connected

Heating: Oil-fired central heating

Drainage: Septic tank

EPC Rating: D

Council Tax Band: G





OUTSIDE AND GROUNDS

The property enjoys delightful gardens and grounds extending to approximately 1.3 acres, offering a wonderful lifestyle setting for families and outdoor entertaining. Adjoining the house is a paved patio terrace ideal for alfresco dining, whilst the gardens also include:

- Kitchen garden
- Firepit seating area with log seating
- Extensive lawns
- Greenhouse
- Garden shed
- Wood store

For those with equestrian interests, the property includes a double stable block, tack room and fenced paddock.

Additional outbuildings include a detached double garage and a timber-built home gym with French doors, which could equally serve as a home office or studio.



The
LEE, SHAW
Partnership

IMPORTANT: We would like to inform prospective purchasers that these sales particulars have been prepared as a general guide only. A detailed survey has not been carried out, nor the services, appliances and fittings tested. Room sizes should not be relied upon for furnishing purposes and are approximate. If floor plans are included, they are for guidance only and may not be to scale. If there are any important matters likely to affect your decision to buy, please contact us before viewing the property. We commonly receive referral fees from specialist service partners - an outline of these can be found on www.leeshaw.com/downloads/referral-fees.pdf

Vine Cottage

Approximate Gross Internal Area
175.9 sq m / 1893 sq ft
Annexe = 58 sq m / 624 sq ft
Double Garage = 34.4 sq m / 370 sq ft
Stable Block / Home Gym = 33.5 sq m / 360 sq ft
Total = 301.8 sq m / 3247 sq ft

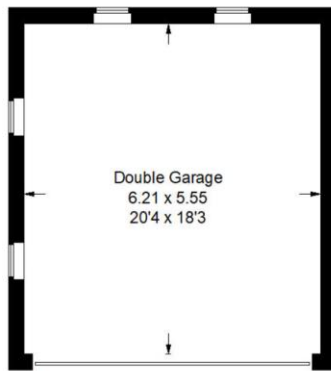
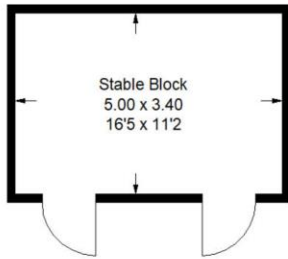

(Not Shown In Actual Location / Orientation)

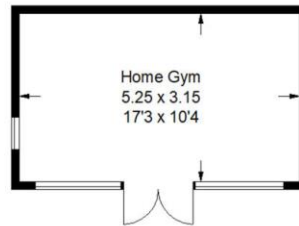

= Reduced headroom below 1.5 m / 5'0

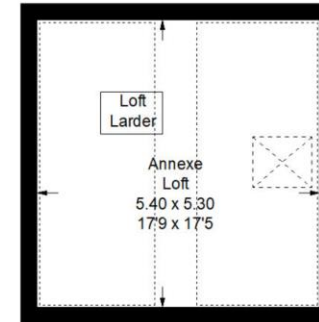

Annexe - First Floor

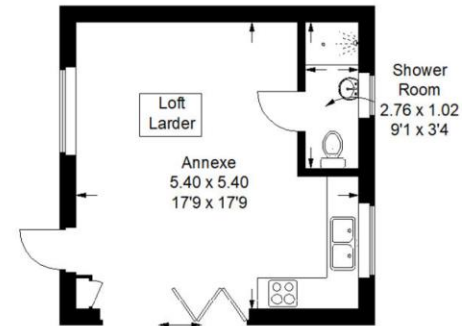

Annexe - Ground Floor

(Not Shown In Actual Location / Orientation)

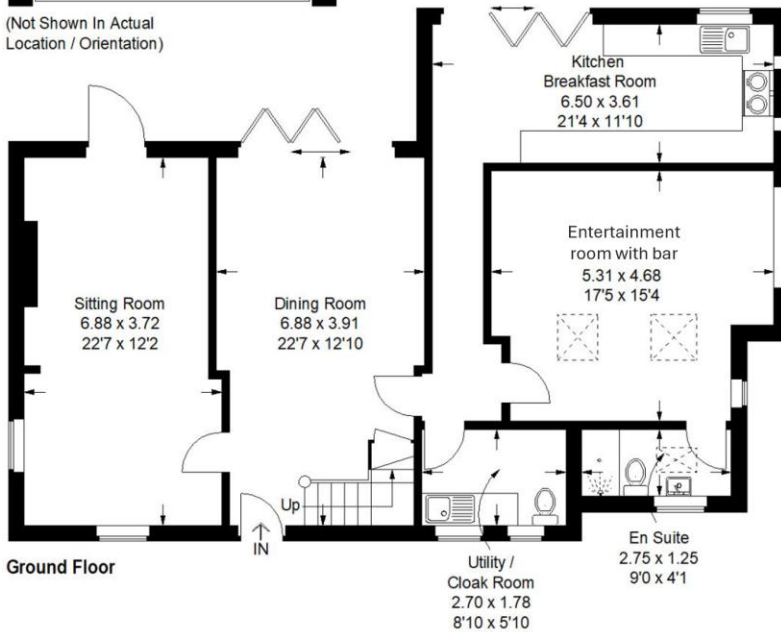

Ground Floor

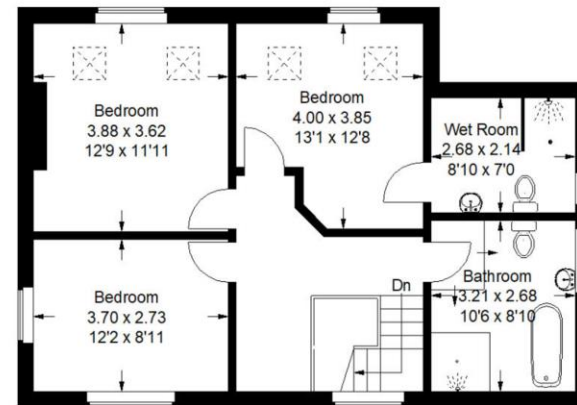

First Floor

The
LEE, SHAW
Partnership

VALUE. SELL. LET.

Selling Agents: The Lee, Shaw PARTNERSHIP

Kempson House, 101 Worcester Road West Hagley,
Worcestershire DY9 0NG

Sales: (01562) 888111
hagley@leeshaw.com
www.leeshaw.com

In accordance with The Money Laundering, Terrorist Financing and Transfer of Funds (Information on the Payer) Regulations 2017, we are legally required to carry out anti-money laundering (AML) checks on all individuals purchasing a property. In line with HMRC guidelines, our trusted partner, Coadjute, will securely manage these checks to include PEP and Sanctions [chehttps://nisgroup.co.uk/wpcontent/uploads/2025/08/TPOL_008-Complaints-Policy.pdf](https://nisgroup.co.uk/wpcontent/uploads/2025/08/TPOL_008-Complaints-Policy.pdf)cks, biometric ID verification and verification of the source of purchase funds, on our behalf. Once an offer is agreed, Coadjute will send a secure link for you to complete the biometric checks electronically. A nonrefundable fee of £45 plus VAT will be charged (per individually named purchaser, including parties gifting deposits) for each AML check conducted, and Coadjute will handle the payment for this service. These (AML) checks must be completed before the property is marked as subject to contract and prior to issuing the memorandum of sale to the solicitors, to confirm the sale. Please contact the office if you have any questions in relation to this.