

Buy. Sell. Rent. Let.

lovelle



3 Charles Street, Lincoln LN5 7LZ



When it comes to  
property it must b

  
lovelle



Asking Price - £120,000



2-bed terrace on Charles St, Lincoln, needs modernisation, sold empty, perfect for first-time buyers or investors. \*CLICK ON OUR INTERACTIVE VIRTUAL 360 TOUR\*

### Key Features

- 2-bed terrace on Charles St, Lincoln
- Separate dining room and lounge
- Galley kitchen
- Requires modernisation throughout
- Outdoor storage in rear garden
- Ideal project for first-time buyers and investors
- EPC rating TBC
- Tenure: Freehold.
- Council Tax Band : A





Introducing a 2-bedroom terrace property on Charles Street, Lincoln. This residence features a separate dining room and lounge, along with a galley kitchen including integrated fridge. Upstairs, you'll find two bedrooms and a bathroom. With partially boarded loft space, the property also includes an outdoor storage area and outdoor WC in the rear courtyard garden.

Sold empty and with no chain, this house is in need of modernisation throughout. Ideal for first-time buyers and investors seeking a project, this property offers an opportunity to update and customise to personal preferences. The outdoor storage and courtyard provide functional spaces. Contact us to schedule a viewing and explore the potential of this property. The property also benefits from Gas Central Heating.

## Agent Notes

These particulars are for guidance only. Lovelle Estate Agency, their clients and any joint agents give notice that:-

They have no authority to give or make representation/warranties regarding the property, or comment on the SERVICES, TENURE and RIGHT OF WAY of any property.

These particulars do not form part of any contract and must not be relied upon as statements or representation of fact.

All measurements/areas are approximate. The particulars including photographs and plans are for guidance only and are not necessarily comprehensive.



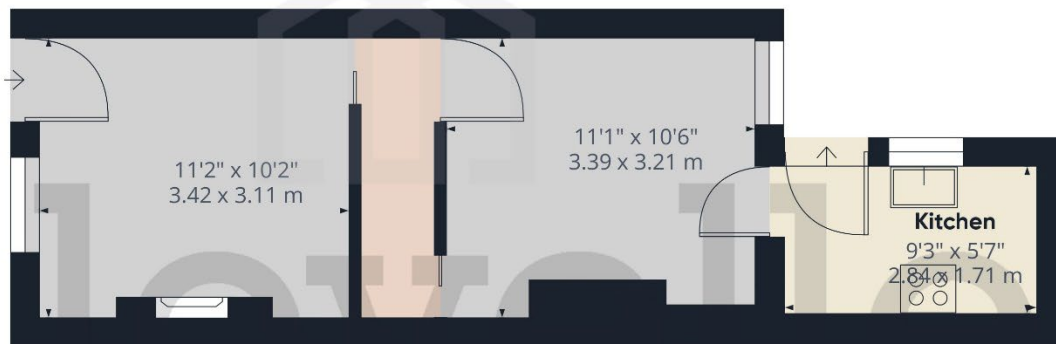

Ground Floor

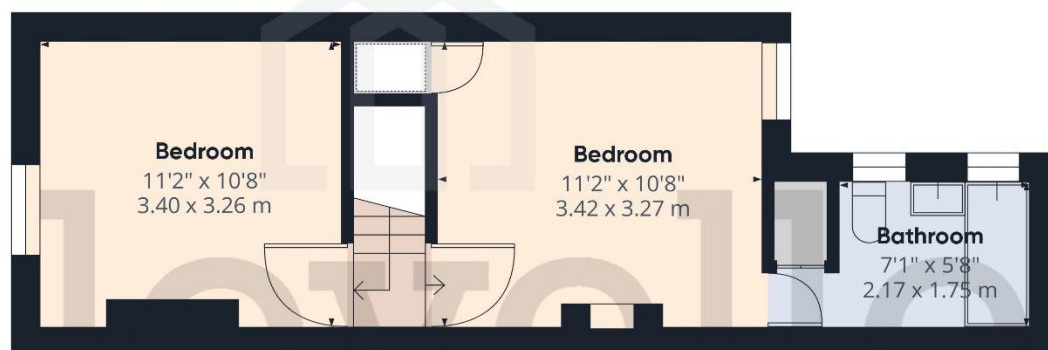

Floor 1

Approximate total area<sup>®</sup>  
602.11 ft<sup>2</sup>  
55.94 m<sup>2</sup>

Excluding balconies and terraces

While every attempt has been made to ensure accuracy, all measurements are approximate, not to scale. This floor plan is for illustrative purposes only.

GIRAFFE360

When it comes to **property**  
it must be



01522 305605

lincoln@lovelle.co.uk