

SNELLERS

ESTATE AGENTS



Fulwell Park Avenue, TW2

£525,000

This family home is the perfect blank canvas. The property has an open plan living / dining room with a separate kitchen, three bedrooms, bathroom and garden with views over The River Crane and nature trail. There is potential to extend out the back and into the loft (STPP).

Fulwell Park Avenue backs onto Crane Park and is only half a mile to the popular Waldegrave School. It is also less than a mile from Whitton and Fulwell Stations. Hampton Hill and Twickenham high street are both just over a mile away.

- No Onward Chain • 1930s Home • Potential To Extend STPP •
- Three Bedrooms • Off-street Parking • 0.5m to Waldegrave School •

SNELLERS

ESTATE AGENTS

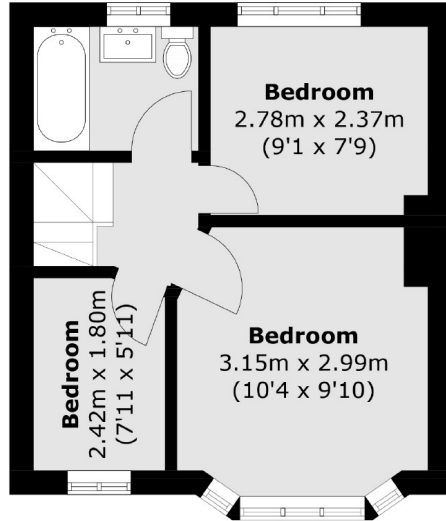

First Floor

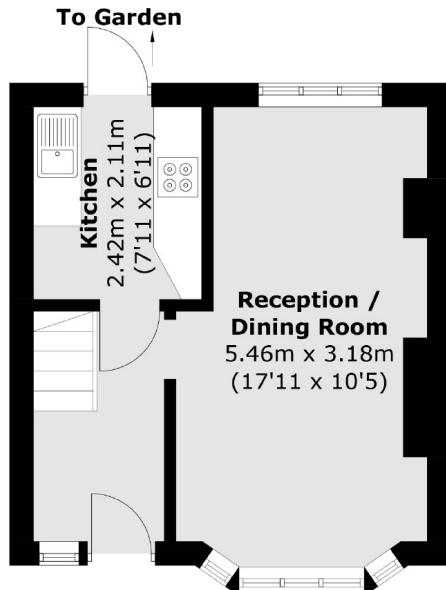

Ground Floor

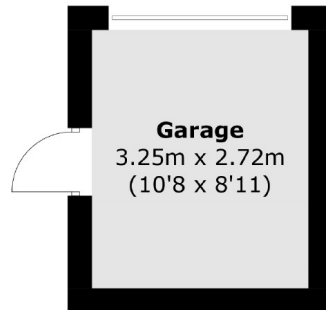

**(Not Shown In Actual
Location / Orientation)**

Total area (approx.): 56.2 sq. m (604.9 sq. ft)
Garage (approx.): 9.0 sq. m (96.9 sq. ft)

Snellers Twickenham Sales
64-66 Heath Road
Twickenham
TW1 4BX
020 8892 5555
twickenhamsales@snellers.co.uk

Energy Rating: D We aim to make our particulars both accurate and reliable. However they are not guaranteed; nor do they form part of an offer or contract. If you require clarification on any points then please contact us, especially if you're traveling some distance to view. Please note that appliances and heating systems have not been tested and therefore no warranties can be given as to their good working order