



## 4 Bed House - Detached

65 Brackley Gate, Morley, DE7 6DJ  
Offers Around £939,950 Freehold



4



3



2



C

**Fletcher  
& Company**

[www.fletcherandcompany.co.uk](http://www.fletcherandcompany.co.uk)

- Beautiful Detached Country Home
- Peaceful & Tranquil Setting
- Lounge & Garden Room
- Superb Living Kitchen/Dining Room
- Four Double Bedrooms, Two Bathrooms
- Landscaped South Facing Private Gardens, Summerhouse, Sheds
- Paddock ( approx. 1 Acre )
- Large Gated Driveway for Approx. 9 Vehicles
- Double Garage with Laundry/Utility
- No Chain Involved

COUNTRY HOME & PADDOCK - Beautiful detached residence with private south facing garden and one acre paddock located in a peaceful tranquil setting within the highly sought after hamlet of Morley.

The property is positioned along an attractive tree-lined and is nicely situated close to open countryside and woodland. It also benefits from being not overlooked to both the front and rear of the property.

#### The Location

Brackley Gate is a particularly sought after area in Morley and in turn approximately 2 miles from the village of Breadsall which is 3 miles from Derby city centre. Excellent local leisure facilities close by include Breadsall Priory with its leisure facility and golf course and there are additional golf courses at Morley Hayes and Horsley Lodge. The village also has the benefit of a reputable primary school and village inns. Private education include Trent college, The Old Vicarage, Derby High School and Derby Grammar School for boys. For those who enjoy the outdoor pursuits the nearby countryside provides some delightful scenery and walks.

#### Accommodation

##### Ground Floor

##### Entrance Porch

With front door, matching double glazed windows with fitted blinds and tiled flooring.

##### Hallway

11'1" x 7'2" (3.38 x 2.19)

With matching tiled flooring, spotlights to ceiling, radiator, fitted storage cupboard, two double glazed Velux style windows, double glazed window overlooking private garden, built-in storage cupboard with shelving and open archway leading into inner hall.

### Inner Hall

14'3" x 14'2" (4.35 x 4.32)

With matching tiled flooring and radiator.



### Lounge

20'5" x 13'6" (6.23 x 4.13)

With chimney breast incorporating log burning stove, matching tiled flooring, spotlights to ceiling, radiator, double glazed window with fitted blind and aspect to front, countryside views, internal double opening oak veneer doors with chrome fittings and wide square archway leading into garden room.



### Garden Room

17'10" x 10'11" (5.45 x 3.34)

With matching tiled flooring, radiator and double glazed windows with very pleasant views of the private rear garden and beyond.



### Living Kitchen/Dining Room

19'8" x 18'4" (6.01 x 5.60)



### Dining Area

With tiled flooring, wine cooler, storage cupboards with matching granite worktops, spotlights to ceiling, double glazed window and feature double glazed bi-folding doors opening onto resin patio and most wonderful private gardens.

### Kitchen Area

With one and a half sink unit with chrome mixer tap, a good range of fitted wall and base cupboards providing good storage with granite worktops, the continuation of the granite worktops forming a useful breakfast bar area, built-in Siemens five ring gas hob with Siemens extractor hood over, built-in Miele coffee machine, built-in Siemens electric fan assisted oven, built-in Siemens combination oven, integrated Siemens fridge/freezer, matching tiled flooring, spotlights to ceiling, radiator, kickboard lighting and double glazed window with pleasant views towards private garden.



### Boiler Area

6'4" x 3'9" (1.95 x 1.15)

With Worcester Greenstar CDi Highflow 550 boiler, matching tiled flooring, double glazed window and double glazed door giving access to garden.

### Double Bedroom One

14'5" x 14'4" (4.41 x 4.39)

With a good range of wardrobes (included in the sale) with matching dressing table, chest of drawers and bedside cabinets, radiator, double glazed window with fitted blind and aspect to front, countryside views, fitted large mirror and internal oak veneer door with chrome fittings.



### Double Bedroom Two

12'5" x 11'5" (3.80 x 3.48)

(Currently used as a large study) with fitted wardrobes providing good storage, matching fitted corner desk with fitted base cupboard underneath, radiator, spotlights to ceiling, double glazed window with fitted blind and internal oak veneer door with chrome fittings.



## Family Bathroom

10'4" x 6'0" (3.17 x 1.84)

A four-piece bathroom with roll edge slipper bath and chrome mixer tap/hand shower attachment, fitted washbasin, low level WC, walk-in double shower with chrome fittings including shower, attractive fully tiled walls with matching tiled flooring, heated chrome towel rail/radiator, spotlights to ceiling, double glazed obscure window and internal oak veneer door with chrome fittings.



## Inner Hallway

9'0" x 2'9" (2.75 x 0.86)

With stairs leading to bedroom three, bedroom four and shower room.

## First Floor

### Double Bedroom Three

18'0" x 11'3" (5.49 x 3.45)

With fitted wardrobes, radiator, spotlights to ceiling, double glazed Velux window, double glazed window to front with fitted blind, countryside views and internal door with chrome fittings.



### Double Bedroom Four

17'11" x 11'0" (5.48 x 3.37)

With fitted wardrobes, radiator, spotlights to ceiling, double glazed Velux window, double glazed window with fitted blind and aspect to rear, pleasant views across private gardens and beyond and internal door with chrome fittings.



### Shower Room

7'0" x 6'8" (2.14 x 2.05)

With separate shower cubicle with chrome shower, fitted washbasin with fitted base cupboard underneath, low level WC, tiled splash-backs, radiator, extractor fan, spotlights to ceiling, double glazed Velux window and internal door with chrome fittings.



### Formal Gardens

The property enjoys a generous sized garden with shaped lawns complemented by raised beds with rockery and attractive large resin patio area providing an excellent sitting out and entertaining space, including a Hot Tub.

### Adjoining Paddock

The property benefits from an adjoining paddock to the rear, approximately one Acre, mainly grassed with a small gathering of woodland.

### Summerhouse

12'6" x 6'9" (3.82 x 2.06)

With power and lighting.

### Shed One

10'10" x 8'9" (3.31 x 2.67)

### Shed Two

10'9" x 8'7" (3.28 x 2.63)

### Large Driveway

Being of a major asset and sale to this particular property is its superb large tarmac driveway with block paved edging providing car standing spaces for approximately nine cars, complete with two remote controlled wrought iron gates.

### Double Garage

20'5" x 14'7" x 11'8" x 10'0" (6.23 x 4.45 x 3.56 x 3.07)

With power and lighting, two front doors and rear personnel door.

### Utility/Laundry

11'1" x 9'10" (3.40 x 3.02)

With plumbing for automatic washing machine, power and lighting.

### Council Tax Band E - Erewash

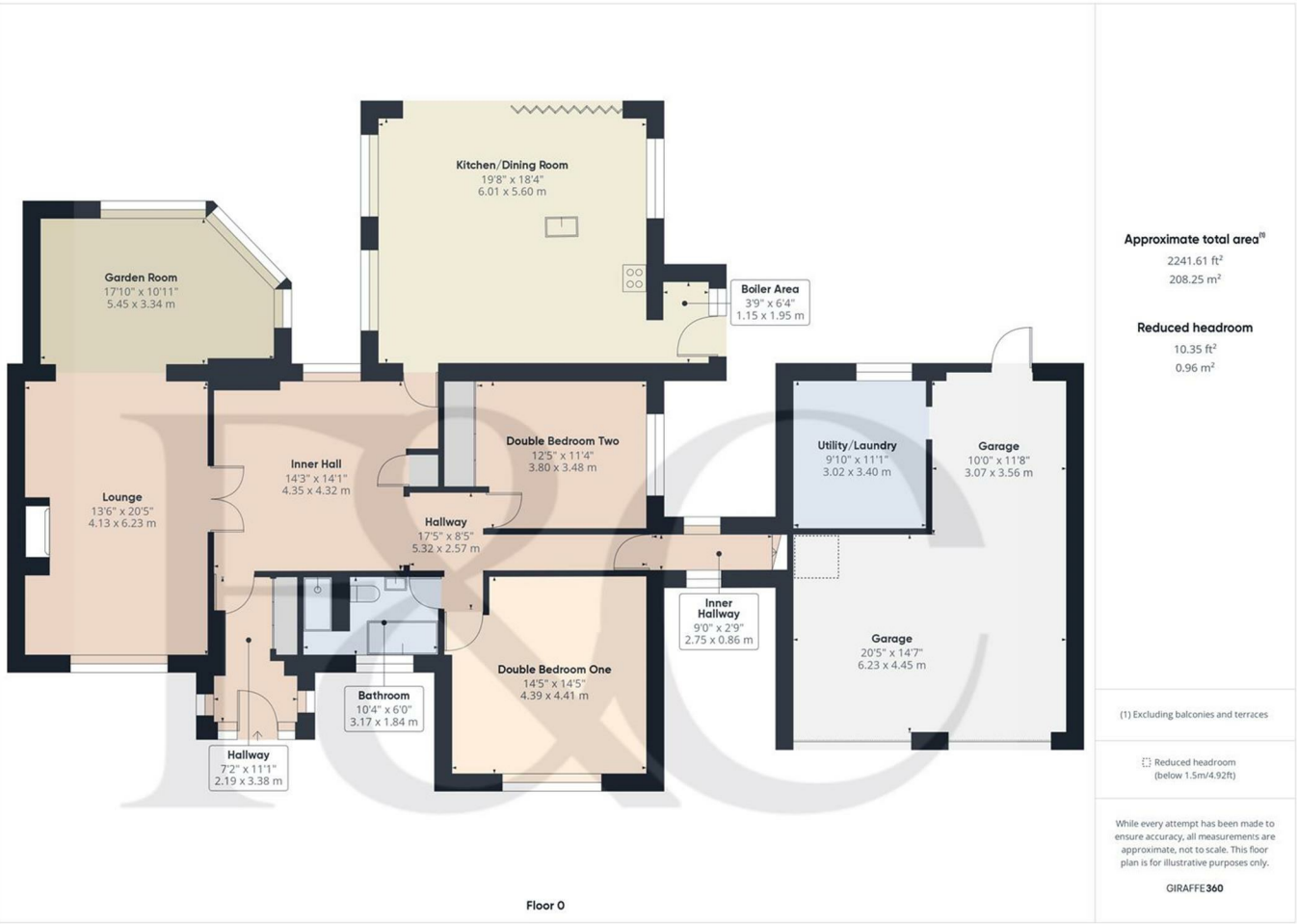

These particulars do not constitute an offer or a contract neither do they form part of an offer or contract. The vendor does not make or give and Messrs. Fletcher & Company nor any person employed has any authority to make or give any representation or warranty, written or oral, in relation to this property. Whilst we endeavour to make our sales details accurate and reliable, if there is any point which is of particular importance to you, please contact the office and we will be pleased to check the information for you, particularly if contemplating travelling some distance to view the property. None of the services or appliances to the property have been tested and any prospective purchasers should satisfy themselves as to their adequacy prior to committing themselves to purchase.

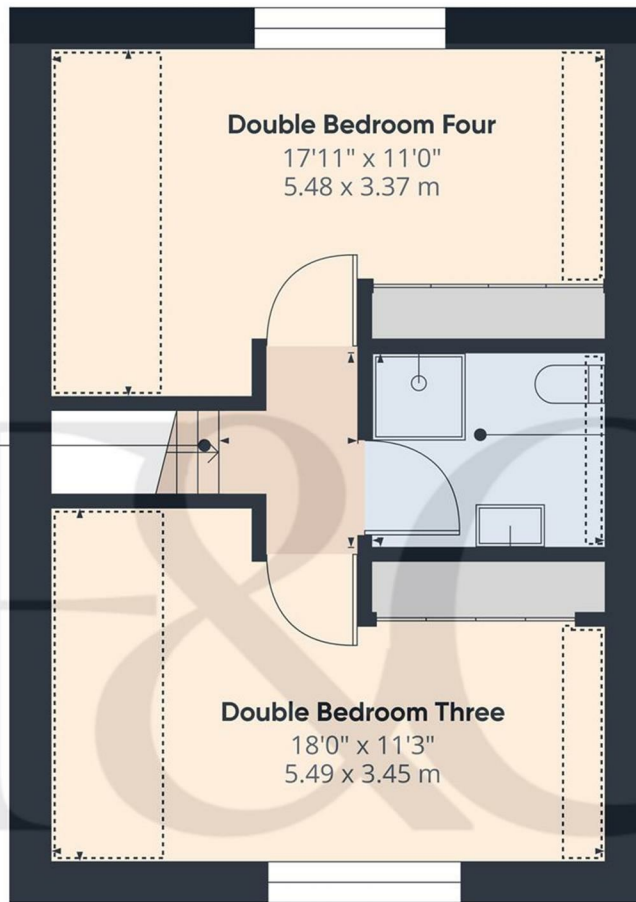

**Landing**  
 4'6" x 5'8"  
 1.39 x 1.75 m

**Shower Room**  
 7'0" x 6'8"  
 2.14 x 2.05 m

**Approximate total area<sup>(1)</sup>**  
 428.51 ft<sup>2</sup>  
 39.81 m<sup>2</sup>

**Reduced headroom**  
 99.1 ft<sup>2</sup>  
 9.21 m<sup>2</sup>

(1) Excluding balconies and terraces

☐ Reduced headroom  
 (below 1.5m/4.92ft)

While every attempt has been made to ensure accuracy, all measurements are approximate, not to scale. This floor plan is for illustrative purposes only.

GIRAFFE360

Floor 1

These particulars do not constitute an offer or a contract neither do they form part of an offer or contract. The vendor does not make or give and Messrs. Fletcher & Company nor any person employed has any authority to make or give any representation or warranty, written or oral, in relation to this property. Whilst we endeavour to make our sales details accurate and reliable, if there is any point which is of particular importance to you, please contact the office and we will be pleased to check the information for you, particularly if contemplating travelling some distance to view the property. None of the services or appliances to the property have been tested and any prospective purchasers should satisfy themselves as to their adequacy prior to committing themselves to purchase.



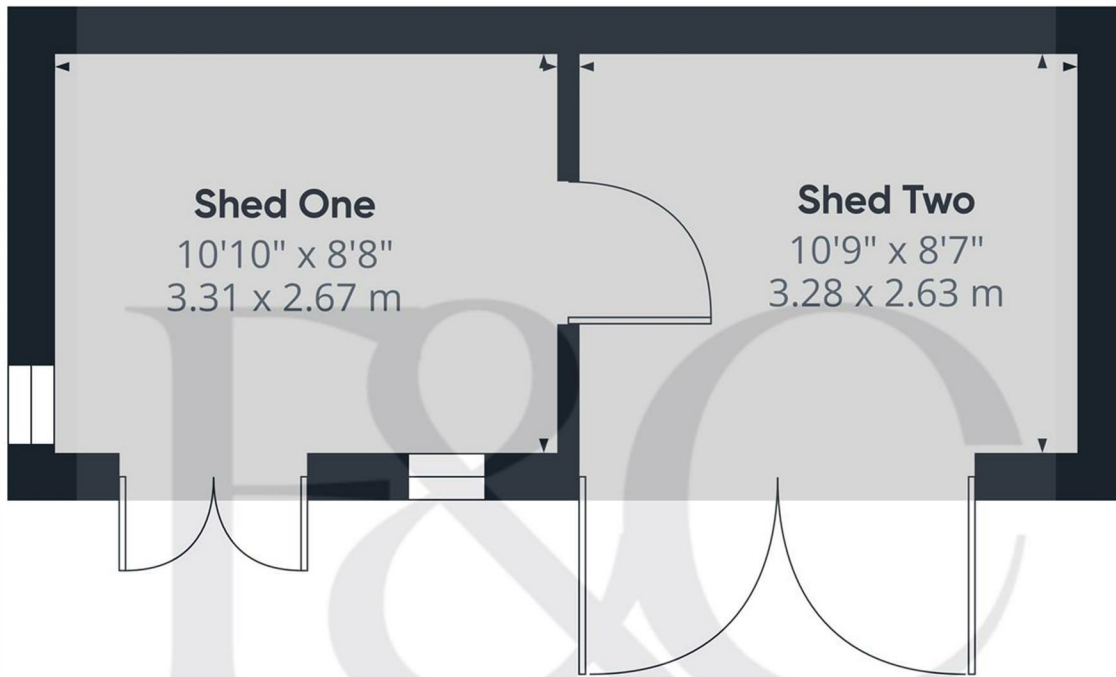

Approximate total area<sup>(1)</sup>  
186.36 ft<sup>2</sup>  
17.31 m<sup>2</sup>

(1) Excluding balconies and terraces

While every attempt has been made to ensure accuracy, all measurements are approximate, not to scale. This floor plan is for illustrative purposes only.

GIRAFFE360

These particulars do not constitute an offer or a contract neither do they form part of an offer or contract. The vendor does not make or give and Messrs. Fletcher & Company nor any person employed has any authority to make or give any representation or warranty, written or oral, in relation to this property. Whilst we endeavour to make our sales details accurate and reliable, if there is any point which is of particular importance to you, please contact the office and we will be pleased to check the information for you, particularly if contemplating travelling some distance to view the property. None of the services or appliances to the property have been tested and any prospective purchasers should satisfy themselves as to their adequacy prior to committing themselves to purchase.

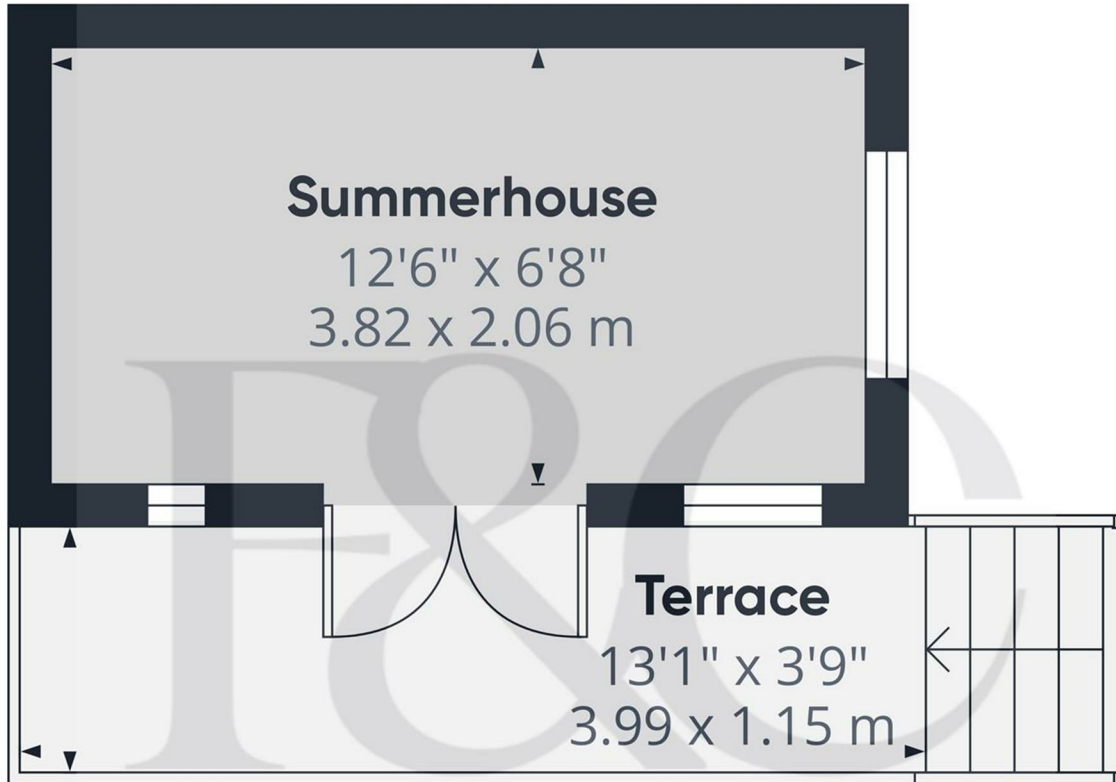

Approximate total area<sup>1)</sup>  
85.11 ft<sup>2</sup>  
7.91 m<sup>2</sup>

(1) Excluding balconies and terraces

While every attempt has been made to ensure accuracy, all measurements are approximate, not to scale. This floor plan is for illustrative purposes only.

GIRAFFE360

### Energy Efficiency Rating

	Current	Potential
<i>Very energy efficient - lower running costs</i>		
(92 plus) <b>A</b>		
(81-91) <b>B</b>		
(69-80) <b>C</b>	<b>71</b>	<b>78</b>
(55-68) <b>D</b>		
(39-54) <b>E</b>		
(21-38) <b>F</b>		
(1-20) <b>G</b>		
<i>Not energy efficient - higher running costs</i>		
<b>England &amp; Wales</b>	EU Directive 2002/91/EC	

### Environmental Impact (CO<sub>2</sub>) Rating

	Current	Potential
<i>Very environmentally friendly - lower CO<sub>2</sub> emissions</i>		
(92 plus) <b>A</b>		
(81-91) <b>B</b>		
(69-80) <b>C</b>		
(55-68) <b>D</b>		
(39-54) <b>E</b>		
(21-38) <b>F</b>		
(1-20) <b>G</b>		
<i>Not environmentally friendly - higher CO<sub>2</sub> emissions</i>		
<b>England &amp; Wales</b>	EU Directive 2002/91/EC	

These particulars do not constitute an offer or a contract neither do they form part of an offer or contract. The vendor does not make or give and Messrs. Fletcher & Company nor any person employed has any authority to make or give any representation or warranty, written or oral, in relation to this property. Whilst we endeavour to make our sales details accurate and reliable, if there is any point which is of particular importance to you, please contact the office and we will be pleased to check the information for you, particularly if contemplating travelling some distance to view the property. None of the services or appliances to the property have been tested and any prospective purchasers should satisfy themselves as to their adequacy prior to committing themselves to purchase.