



Clovers, Stableford, Bridgnorth, Shropshire, WV15 5LS

BERRIMAN
EATON





Clovers, Stableford, Bridgnorth, Shropshire, WV15 5LS

Clovers is a quintessential cottage of magnificent history, with charming features throughout, offering 4 bedroom accommodation. Surrounded by beautiful mature gardens in the hamlet of Stableford this is an ideal location for those who enjoy countryside living and walks, yet remaining commutable to the West Midlands.
Bridgnorth - 6 miles, Telford - 9 miles, Shrewsbury - 26 miles, Kidderminster - 17 miles, Stourbridge - 14 miles, Wolverhampton - 13 miles, Birmingham - 25 miles. (All distances are approximate).

CLOVERS
STABLEFORD, SHROPSHIRE

HOUSE: 168.1sq.m. 1,809.8sq.ft.
GARAGE: 17.1sq.m. 184.3sq.ft.
TOTAL: 185.2sq.m. 1,994.1sq.ft.
INTERNAL FLOOR AREAS ARE APPROXIMATE
FOR GENERAL GUIDANCE ONLY - NOT TO SCALE
POSITION & SIZE OF DOORS, WINDOWS, APPLIANCES
AND OTHER FEATURES ARE APPROXIMATE

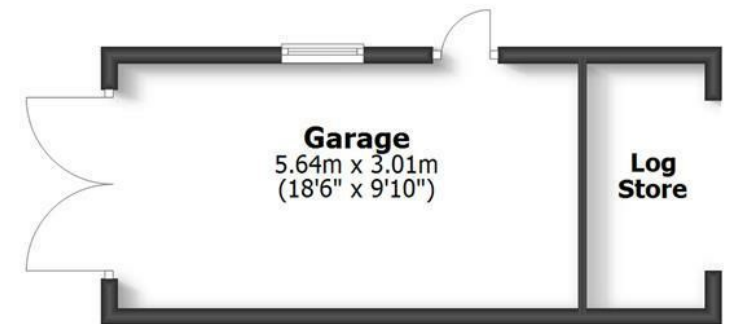
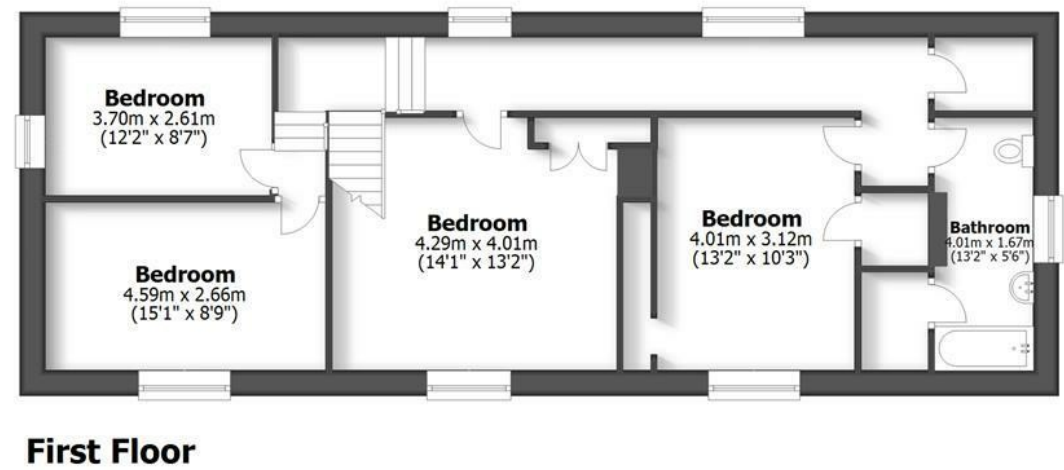
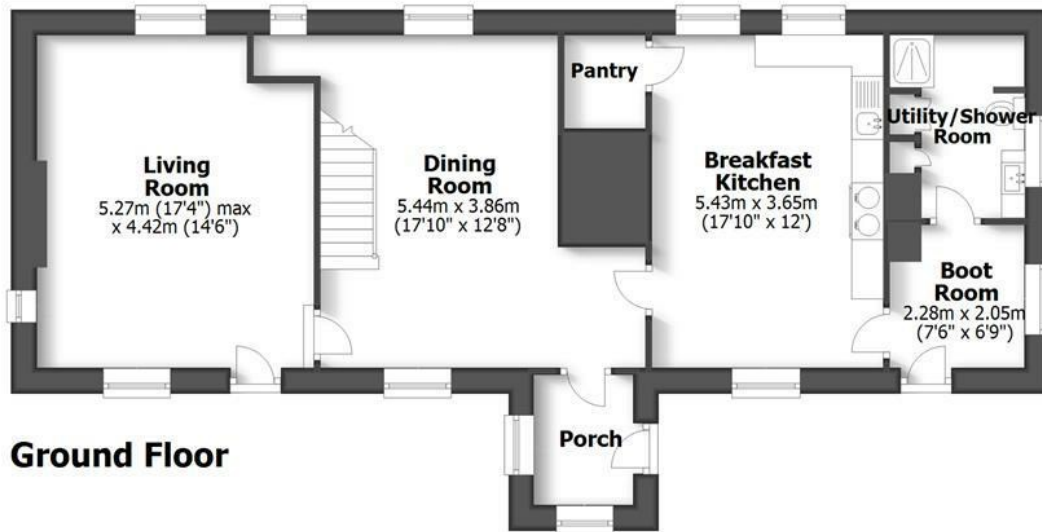

LOCATION

The cottage sits in a private and tranquil position of around half an acre, near Stableford Hall. This quintessential Hamlet between Worfield and Badger couldn't be more convenient being just off the B4176 Telford to Wolverhampton Road, within 10 minutes of Bridgnorth, Telford and 15 minutes from Wolverhampton or the M54 junction 4. There are good local pubs within a short bike ride and the cottage falls into the parish of Worfield with its 12th Century spired Church and Ofsted 'Good' rated primary school and nursery.

ACCOMODATION

Grade II Listed and originally 3 cottages, the detached 17th Century home has been modernised and impeccably maintained, Clovers features outstanding charm throughout and each window enjoys views across this pretty cottage garden with far reaching countryside views beyond. Rooms have exposed original beams and doors,

On entering the property the hall provides a boot room space and gives access to a ground floor shower room/utility.

The farmhouse style breakfast kitchen has a bespoke range of oak panelled fitted units with granite work tops, ceiling spot lights and a quarry tiled floor. Integrated are an electric Aga, dishwasher, Belfast sink and pantry off. Proceeding into the dining room, a half-glazed door gives access to the porch which has an additional front door access. The dining room has a large feature fireplace with small woodstove, while stairs lead up to the first floor. Access leads into the large main living room with an installed log burner that is beside the original bread oven. A living room door opens into the front garden garden.

Stairs rise to the first floor with a split landing (NB there is a very low beam on the landing). The principal bedroom has lovely views and wardrobes. There are three further bedrooms, one having a walk in cupboard and there is a family bathroom having a bath with mixer shower over, WC and hand basin. Additionally there is a large airing cupboard and walk-in storeroom off the landing.

OUTSIDE

The property has gardens of around half an acre surrounding the cottage, beautifully landscaped and designed for seasonal colour with mature shrubs and trees. Features include a wooden pergola, summerhouse, multiple vegetable patches, a pond and a composting area. There are several out buildings for storage including pigsties and a more modern garage. The private driveway provides a large parking area.

SERVICES

We are advised by our client that mains water, drainage and electricity are connected. Oil fired central heating. Verification should be obtained by your Surveyor.

TENURE

We are advised by our client the property is FREEHOLD. Verification should be obtained by your Solicitor.

COUNCIL TAX

Shropshire Council. Tax Band: G
<https://www.gov.uk/council-tax-bands>

Lease details, service charges, ground rent (where applicable) and council tax are given as a guide only and should be checked and confirmed by your Solicitor prior to exchange of contracts.

VIEWING ARRANGEMENTS

Viewing strictly by appointment only, please call the BRIDGNORTH OFFICE.

FIXTURES AND FITTINGS

By separate negotiation.

POSSESSION

Vacant possession will be given on completion.

DIRECTIONS

Leaving Bridgnorth on the A454 the property is accessed via the B4176 then the turn signposted to Badger. Continue for a short distance taking the next left turn onto a private driveway shared with two bungalows that then leads onto a private gravelled drive with good parking.

Offers Around £725,000

EPC:

IMPORTANT NOTICE: Every care has been taken with the preparation of these Particulars but they are for general guidance only and complete accuracy cannot be guaranteed. Areas, measurements and distances are approximate and the text, photographs and plans are for guidance only. If there is any point which is of particular importance please contact us to discuss the matter and seek professional verification prior to exchange of contracts.







Tettenhall Office
01902 747744
tettenhall@berrimaneaton.co.uk

Bridgnorth Office
01746 766499
bridgnorth@berrimaneaton.co.uk

Wombourne Office
01902 326366
wombourne@berrimaneaton.co.uk

Worcestershire Office
01562 546969
[worcestershires@berrimaneaton.co.uk](mailto:worcestershire@berrimaneaton.co.uk)

Lettings Office
01902 749974
lettings@berrimaneaton.co.uk

BERRIMAN EATON