

...Your proactive estate agent



Woodlands Crescent, Hemsworth, Pontefract, WF9 5LH
Offers Over £185,000



****THREE BEDROOMS**** GENEROUS DRIVE with GARAGE ****GARDENS TO FRONT AND REAR**** Bungalow situated in Hemsworth this property briefly comprises: entrance hallway, lounge, kitchen diner, family bathroom, w.c. Central to motorways, ideal for commuting. VIEWING IS HIGHLY RECOMMENDED TO FULLY APPRECIATE THE STYLE OF THE PROPERTY ON OFFER. . CALL 7 DAYS A WEEK TO ARRANGE A VIEWING. THE OFFICE IS OPEN MONDAY TO FRIDAY FROM 9AM UNTIL 5:30PM. SATURDAYS FROM 9AM UNTIL 5PM. PLEASE NOTE, OUR PHONE LINES ARE OPEN UNTIL 8PM MONDAY - THURSDAY AND 11AM-3PM SUNDAYS.



GROUND FLOOR ACCOMMODATION

ENTRANCE

ENTRANCE HALLWAY

6.71 x 1.68 (22'0" x 5'6")

Carpeted with double panel central heating radiator and doors leading to:



LOUNGE

5.99 x 2.98 (19'7" x 9'9")

Double panel central heating radiator, telephone and television points, fireplace having electric fire and white uPVC double glazed windows to front and side elevation.



KITCHEN DINER

2.65 x 2.57 3.57 x 2.57 (8'8" x 8'5" 11'8" x 8'5")

Having a range of fitted wall and base units in a high gloss grey finish, square edge laminated worktops, integrated electric oven, four ring electric hob and extractor fan. Inset single bowl stainless sink with black pull down mixer tap. Laminate flooring with white uPVC double glazed windows to rear and side elevation. Space and plumbing for dishwasher and washing machine.



BATHROOM

2.36 x 1.50 (7'8" x 4'11")

Three piece fitted suite comprising : White, wall unit w.c., vanity wash hand basin in grey finish with chrome mixer tap, rectangle shower unit with power shower and glass panel. Marble effect uPVC tiles from floor to ceiling, laminate flooring, white uPVC double glazed frosted window to rear elevation and chrome towel radiator.



BEDROOM ONE

3.55 x 3.44 (11'7" x 11'3")

Double panel central heating radiator and white uPVC double glazed window to front elevation.



BEDROOM TWO

3.44 x 3.02 (11'3" x 9'10")

Double panel central heating radiator and white uPVC double glazed window to side elevation.



W.C

1.71 x 0.90 (5'7" x 2'11")

Two piece fitted suite comprising: White wall unit w.c. and vanity wash hand basin in a grey finish with chrome mixer taps. Marble effect uPVC tiles to half way, laminate flooring, white uPVC double glazed frosted window to rear elevation and chrome towel radiator.

BEDROOM THREE

3.12 x 2.90 (10'2" x 9'6")

Double panel central heating radiator and white uPVC double glazed window to rear elevation.



HEATING & APPLIANCES

The heating system and any appliances (including Burglar Alarms where fitted) mentioned in this brochure have not been tested by Park Row Properties. If you are interested in purchasing the property we advise that you have all services and appliances tested before entering a legal commitment to purchase.

MAKING A OFFER

In order to comply with the Estate Agents (Undesirable Practises) Order 1991, Park Row Properties are required to verify "the status of any prospective purchaser... This includes the financial standing of that purchaser and his ability to exchange contracts". To allow us to comply with this order and before recommending acceptance of any offers, and subsequently making the property 'SOLD' each prospective purchaser will be required to demonstrate to 'Park Row Properties' that they are financially able to proceed with the purchase of the property.

We provide truly Independent Mortgage Advice. Unlike many companies we are not tied, and more importantly not targeted to any Lender. We have instant on-line access to over 1000 mortgage deals provided by over 100 Lenders ensuring we are unbeatable when identifying and

recommending your new mortgage or re-mortgage requirements.

Your home is at risk if you do not keep up repayments on a mortgage or other loan secured on it. Written quotations available on request. Life assurance is usually required.

To arrange a no obligation appointment please contact your local office.

MEASUREMENT'S

These approximate room sizes are only intended as general guidance. You must verify the dimensions carefully before ordering carpets or any built-in furniture.

VIEWING'S

Strictly by appointment with the sole agents.

If there is any point of particular importance to you we will be pleased to provide additional information or to make any further enquiries. We will also confirm that the property remains available. This is particularly important if you are travelling some distance to view the property.

TENURE AND COUNCIL TAX BANDING

Please note: The Tenure and Council Tax Banding for the property have been advised by the Vendor or obtained from online sources. We strive to ensure these details are accurate and reliable, however, we advise any potential buyer to carry out their own enquiries before proceeding.

OPENING HOURS

CALLS ANSWERED :

Mon, Tues, Wed & Thurs - 9.00am to 8.00pm

Friday - 9.00am to 5.30pm

Saturday - 9.00am to 5.00pm

Sunday - 11.00am to 3.00pm

TO CHECK OFFICE OPENING HOURS PLEASE CONTACT THE RELEVANT BRANCHES ON:

GOOLE - 01405 761199

SELBY - 01757 241124

SHERBURN IN ELMET - 01977 681122

PONTEFRACT - 01977 791133

CASTLEFORD - 01977 558480

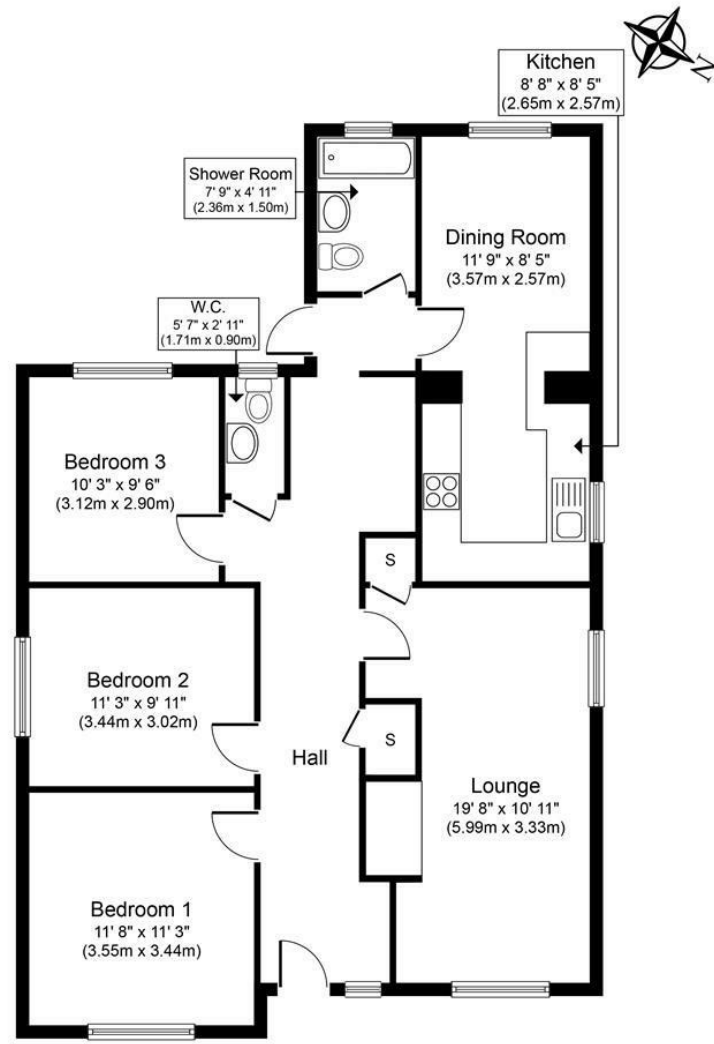

Ground Floor
Approximate Floor Area
1067 sq. ft.
(99.1 sq. m.)

Whilst every attempt has been made to ensure the accuracy of the floor plan contained here, measurements of doors, windows, rooms and any other items are approximate and no responsibility is taken for any error, omission, or mis-statement. The measurements should not be relied upon for valuation, transaction and/or funding purposes. This plan is for illustrative purposes only and should be used as such by any prospective purchaser or tenant. The services, systems and appliances shown have not been tested and no guarantee as to their operability or efficiency can be given.
 Copyright V360 Ltd 2023 | www.houseviz.com

T 01977 791133

W www.parkrow.co.uk

18 Cornmarket, Pontefract, West Yorkshire, WF8 1BJ

pontefract@parkrow.co.uk



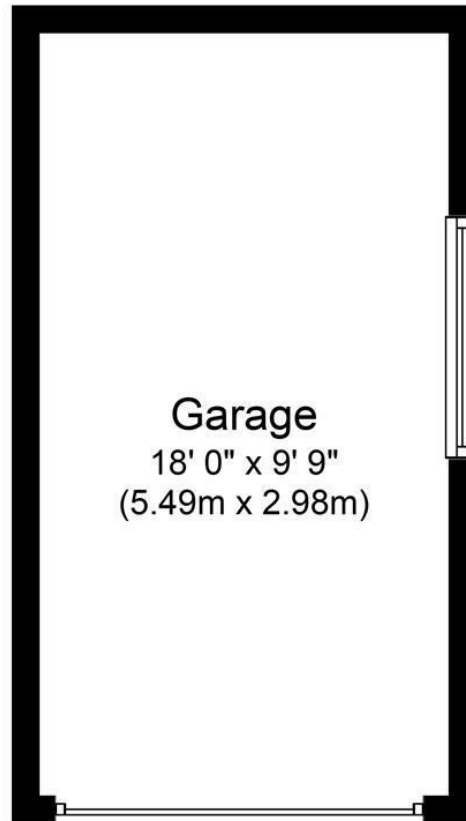

Garage
18' 0" x 9' 9"
(5.49m x 2.98m)

Garage
Approximate Floor Area
178 sq.ft.
(16.5 sq.m.)

Whilst every attempt has been made to ensure the accuracy of the floor plan contained here, measurements of doors, windows, rooms and any other items are approximate and no responsibility is taken for any error, omission, or mis-statement. The measurements should not be relied upon for valuation, transaction and/or funding purposes. This plan is for illustrative purposes only and should be used as such by any prospective purchaser or tenant. The services, systems and appliances shown have not been tested and no guarantee as to their operability or efficiency can be given.
Copyright V360 Ltd 2023 | www.houseviz.com

T 01977 791133

W www.parkrow.co.uk

18 Cornmarket, Pontefract, West Yorkshire, WF8 1BJ

pontefract@parkrow.co.uk

