



FURLONG ROAD LONDON N7
£425 PER WEEK AVAILABLE 10/06/2024

Hamptons

THE HOME EXPERTS

{ THE PARTICULARS

Furlong Road London N7

**£425 Per Week
Furnished**

 **1 Bedroom**
 **1 Bathroom**
 **1 Reception**

Features

- Double Bedroom, - Three Piece Bathroom, - Private Terrace, - Wood Floors, - Quiet Road, - Close to Highbury & Islington Station, - Council Tax - Band D

Council Tax

Council Tax Band D

Hamptons

97-99 Upper Street
Islington, London, N1 ONP
0207 359 5675
islingtonlettings@hamptons-int.com
www.hamptons.co.uk

The Property

We are pleased to offer this top floor period conversion with parquet flooring, modern fittings and natural light throughout whilst benefitting from a large private terrace. The property is only minutes from Highbury and Islington Station, Highbury Fields and the amenities of Upper Street.



FURLONG ROAD

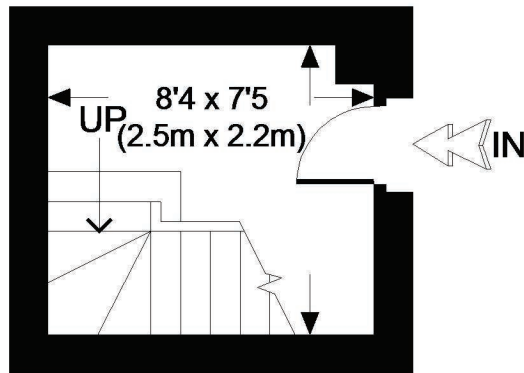
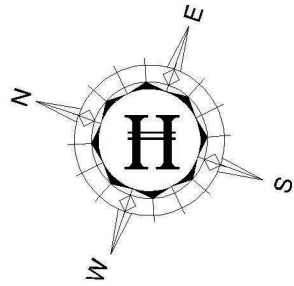

FIRST FLOOR

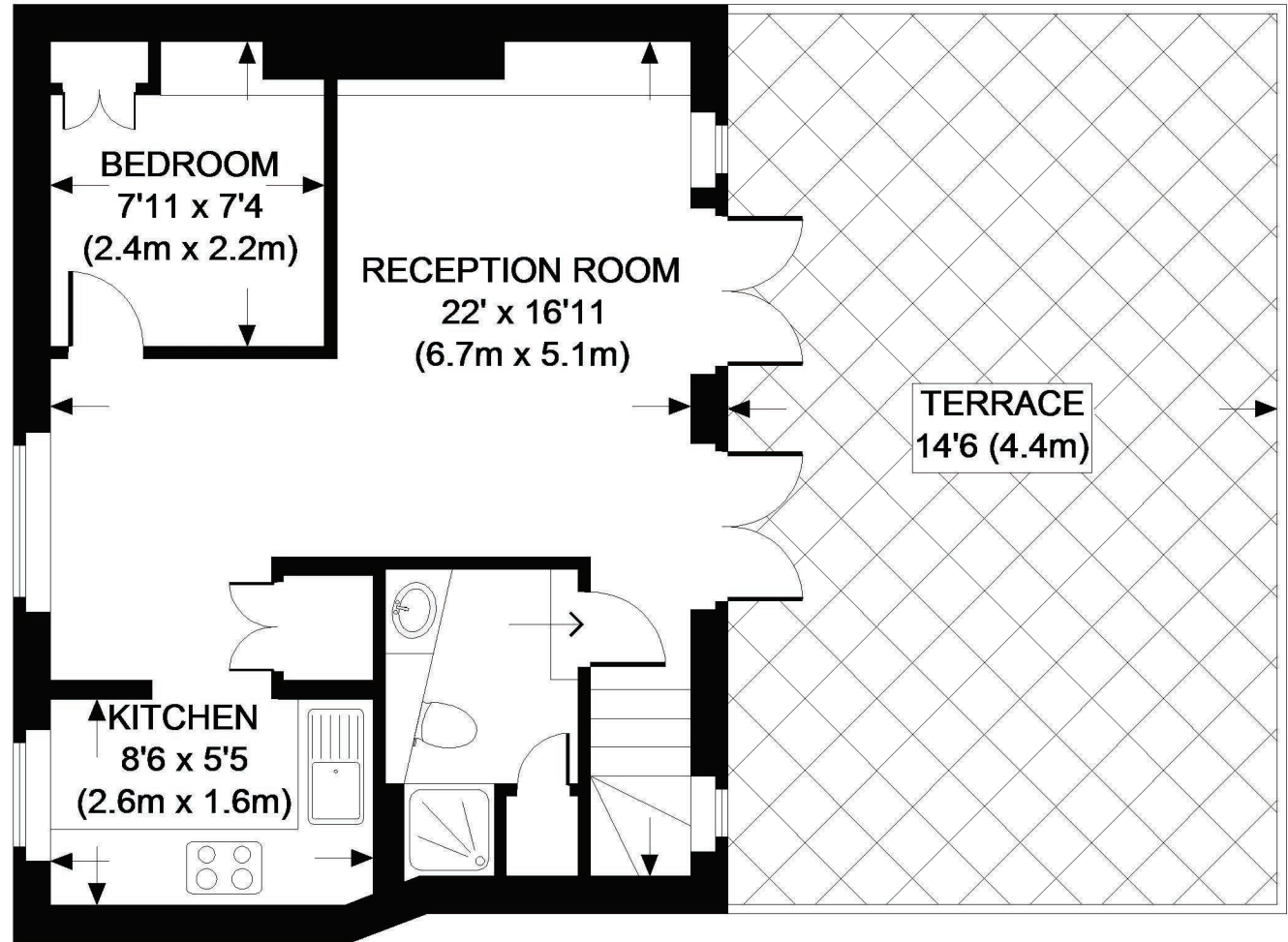

SECOND FLOOR

APPROXIMATE GROSS INTERNAL AREA = 441 SQ.FT. (41 SQ. M.)

This plan is for layout guidance only. Not drawn to scale unless stated. Windows & door openings are approximate. Whilst every care is taken in the preparation of this plan, please check all dimensions, shapes & compass bearings before making any decisions reliant upon it.

Please be advised that Hamptons International / our agents have not seen or reviewed any building regulations or planning permission in relation to works carried out to the property.

For Clarification

We wish to inform prospective tenants that we have prepared these particulars as a general guide and they have been confirmed as accurate by the landlord. We have not verified permissions, nor carried out a survey, tested the services, appliances and specific fittings. Room sizes are approximate and measurement figures rounded: they are taken between internal wall surfaces and therefore include cupboards/shelves, etc. Accordingly, they should not be relied upon for

carpets and furnishings. It should also be noted that all fixtures and fittings, carpeted, curtains/blinds, kitchen equipment and garden statuary, whether fitted or not, are deemed removable by the landlord unless specifically itemised with these particulars. Please enquire in office or on our website for details on holding deposit and tenancy deposit figures.

Energy Efficiency Rating		Current	Potential
100-92	A		
91-82	B		
81-65	C		
64-55	D		
54-45	E	53	
44-35	F		
34-20	G		74

EU Directive 2002/91/EC
England & Wales



Awaiting Photograph

Awaiting Photograph

Awaiting Photograph

Awaiting Photograph