



Solicitors & Estate Agents









Offers Over
£399,995

9 Dundas Road

Eskbank | Midlothian | EH22 3EN

This most impressive, traditional detached bungalow occupies a generous plot including a large mature south-facing rear garden, sizeable front garden, multi-vehicle driveway and single garage. Quietly positioned within the prestigious Eskbank district of Midlothian, within easy reach of excellent amenities and transport links including the nearby Eskbank Train Station with excellent road links leading to the North and South.

-  3 Bedrooms
-  2 Public rooms
-  1 Shower room
-  Substantial Private Gardens
-  Driveway & Garage
-  EPC Rating –D
-  Council Tax Band - F



Description

This delightful, extended home provides the convenience of single-story living, yet offers excellent extension/development potential, subject to the relevant planning permissions being obtained. Undoubtedly appealing to a wide variety of buyers seeking a fine home in an excellent location, this property merits internal viewing to be fully appreciated. Enjoying a light, neutral and well maintained interior, the flexible accommodation comprises; entrance vestibule, welcoming hallway with storage provisions including a part floored attic with Ramsay ladder access. The rear facing lounge/diner offers excellent natural light and is enhanced by solid wood flooring and features a wood burner. The large south-facing conservatory is located off the lounge and enjoys a fantastic aspect over the rear garden. The modern fitted kitchen has ample wall and base units with built-in gas hob with hood above and separate built-in electric double oven. A rear porch/utility room offers useful storage provisions and has an additional door to the side. There are three sizeable double bedrooms, with the principal bay-windowed bedroom enjoying excellent proportions with bedroom 2, currently utilised as a diningroom by the present owners. The shower room comprises of a white three piece suite with shower enclosure with mains shower, WC and wash band basin set in vanity unit with storage. Further benefits include gas central heating, double glazing, loft and cavity wall insulation.



Extras

All the fitted floor coverings, light fittings (excluding the lounge) and blinds shall be included in the sale together with the built-in hob/hood/double oven, fridge freezer, dishwasher and washing machine.

Gardens, driveway & garage

The sizeable front garden is laid with chipstones for ease of maintenance with attractive mature plants and shrubs. A driveway is located to the side providing valuable off-street parking and leads to the single garage with power & light. The fully enclosed south-facing rear garden is a fantastic addition, enjoying a high degree of privacy and laid with two lawns, paved patios with attractive mature borders. The greenhouse and one shed shall be included in the sale.

Viewing

By appointment with Neilsons on 0131 625 2222.





Location

The leafy suburb of Eskbank is located approx. 7 miles from Edinburgh's City Centre and is conveniently positioned for access to excellent commuting links with the A7, A68 and City of Edinburgh Bypass close at hand linking Edinburgh Airport and the West, and to the beautiful villages, beaches and golf courses of East Lothian to the East. Eskbank train station is only a short walk away and there are a wide range of bus routes through Eskbank, with the Park & Ride at Shawfair just a couple of minutes beyond the nearby Sheriffhall roundabout. Edinburgh Royal Infirmary and the Sick Kids Hospital are also within easy reach. There are a host of convenient amenities in close proximity including a large Tesco Superstore with a variety of additional shops, restaurants, cafes, pubs and high street shops available in Dalkeith, just a few minutes drive. Further shopping is available at nearby Straiton and Fort Kinnaird Retail parks. There are great leisure facilities in the surrounding area to enjoy, including a variety of golf courses (Newbattle, Broomieknowe, Kings Acre, Melville), the iconic Dalkeith Country Park, plus beautiful walks in historic Newbattle Woods and Abbey grounds. The house is in the catchment for excellent nursery, primary and secondary schools.





Approx. Gross Internal Floor Area 109.26 Sq M / 1176 Sq Ft.

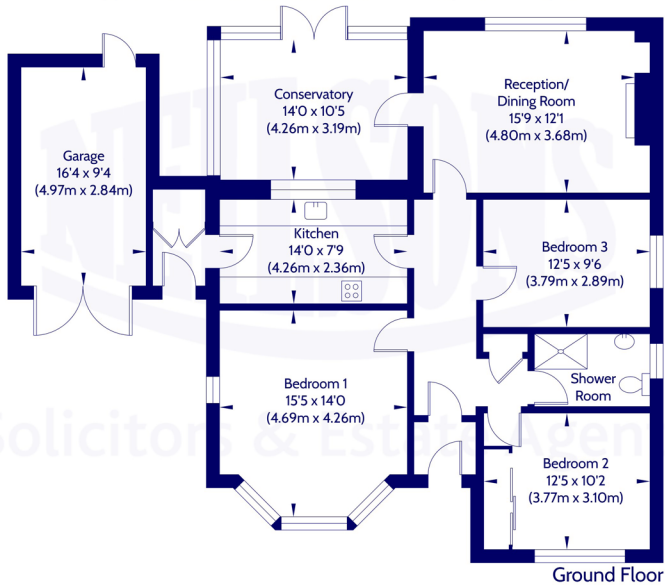

Area excludes garages, outbuildings, attics and eaves if applicable.
All measurements are approximate. Not to scale. For identification only.
© 2024 Neilsons Solicitors & Estate Agents. Plans by Planography.co.uk

Whilst we endeavour to ensure that our sales particulars are accurate and reliable, the following general points should be noted with regard to the extent of our investigations prior to marketing the property and therefore if any particular aspect is of crucial relevance to you, please contact this office for verification particularly if you are contemplating travelling some distance to view.

- [1] All measurements have been taken using a sonic measuring device and there may be some minor fluctuations in measurements due to the limitations of the device.
- [2] None of the items included in the sale of a working or running nature have been tested by us and this Firm gives no warranty as to their condition.
- [3] Where alterations or improvements have been undertaken by the sellers or their predecessors, we have not specifically established that the renewal or replacement of any of the services or facilities have been whole or partial.
- [4] Verification of Council Tax banding can be obtained from City of Edinburgh Council or Public Libraries.



Scan the QR code or [click here](#) for the virtual 360 tour, floor plan and further information.



Solicitors & Estate Agents

Our Services:

- Full estate agency service
- Buying & Selling
- Buy to let advice
- Wills & Powers of Attorney
- Estate Planning
- Executries
- Powers of Attorney

For helpful, friendly, personal advice, get in touch.

✉ mail@neilsons.co.uk

☎ 0131 625 2222

💻 www.neilsons.co.uk

Head Office
138 St John's Road
Edinburgh

Property Department
142 St John's Road
Edinburgh

City Centre
2a Picardy Place
Edinburgh

South Queensferry
37 High Street
South Queensferry

Bonnyrigg
72 High Street
Bonnyrigg

