

BUILDING 5510 ARC OXFORD

OX4 2LH

ARC.

BUILDING 5510 AT A GLANCE

- 26,273 sq ft in total, individual floors from 8,724 sq ft
- New Lab enabled accommodation ready Autumn 2023
- Goods lift
- 115 parking spaces
- Electric vehicle charging points
- EPC available on completion of refurbishment
- Available from Summer 2023

INTRODUCTION

ARC Oxford is home to some of the world's most impactful science and innovation organisations. At the heart of the city's world-leading innovation ecosystem — an integral part of a powerful knowledge economy. Discover offices, co-working, fitted labs and dedicated manufacturing facilities in Oxford city centre on the doorstep of Oxford University and 3 miles from John Radcliffe Hospital.

INTRODUCTION



ARC Oxford is set to grow. 750,000 sq ft of brand new science-ready space — offices, labs, cleanrooms and cutting-edge R&D facilities — will soon evolve the cluster into a world-class environment for science and innovation. It's an investment in ARC's future, Oxford's continued position as a global centre of invention, and the UK's ambition to become a science superpower.

INTRODUCTION

EASILY CONNECTED



3 miles
Oxford Train Station



1 hour
London Paddington



2.3 miles
High Street



8 miles
M40 Junction 8/9



50 minutes
London Heathrow



2.4 miles
Headington Hospitals

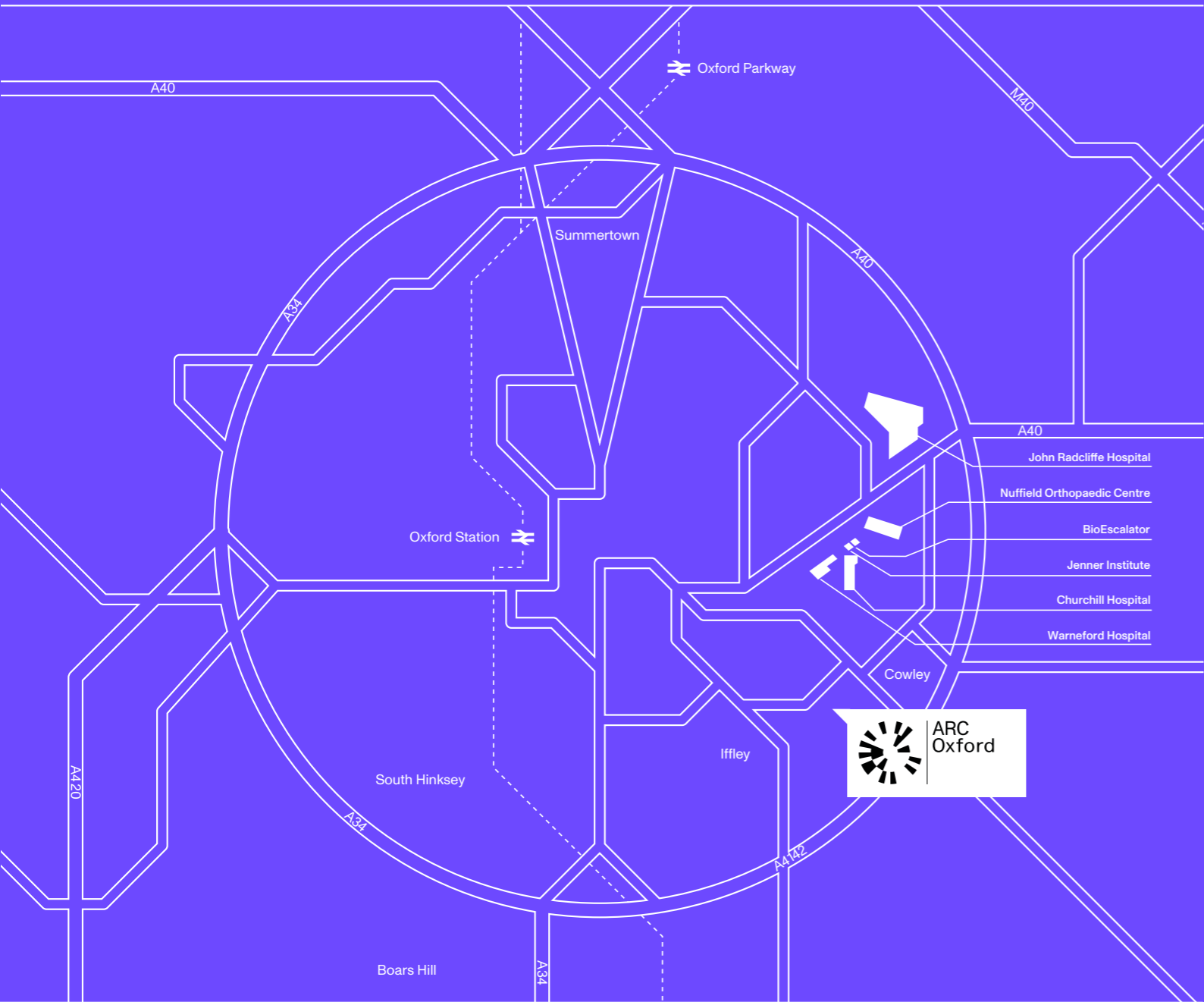

LIFE ON CAMPUS

The Oxford Factory & Works	01	Next	05	Children's Day Nursery	09
The Market Place	02	Boots	06	Longwall Restaurant	10
Tesco	03	Petrol Station	07	David Lloyd Racket & Health Club	11
M&S	04	Premier Inn Hotel	08	Templars Square Shopping Centre	12



BUILDING SPECIFICATION AND FLOORPLANS

Summary

Building 5510 will provide lab-enabled contemporary workspace, totalling 2240.8 sq m (26,273 sq ft) (subject to measurement on completion); set over three floors with 115 car parking spaces. The building will be extensively refurbished and will be delivered to a Lab enable finish ready for an occupiers fitout. Alternatively a fully fitted option is also available by separate negotiation.

Available Summer 2023.

EPC available on completion of refurbishment.

Specification

- Individual floors from 8,724 sq ft
- M&E plant installed for 70% Lab content
- Allowing for 6 air changes per hour
- Refurbished core
- New WC & Shower facilities
- Goods lift
- External plant area
- 115 parking spaces
- Electric vehicle charging points
- EPC available on completion of building works

GROUND FLOOR

8,761 sq ft

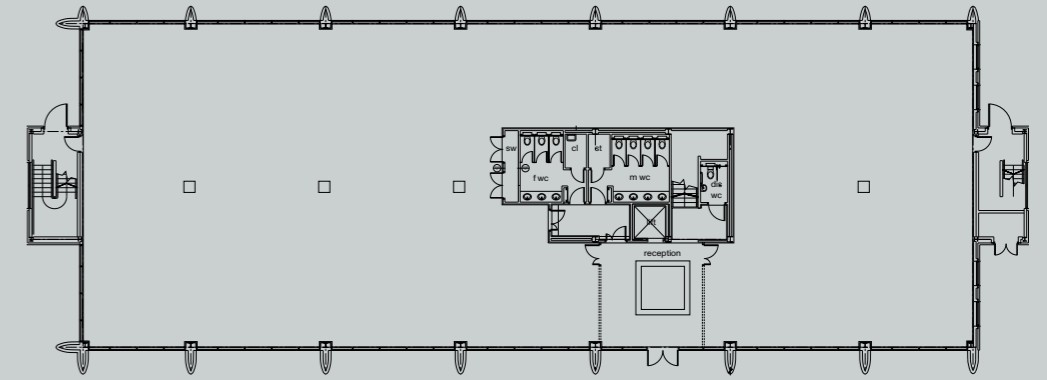

FIRST FLOOR

8,788 sq ft

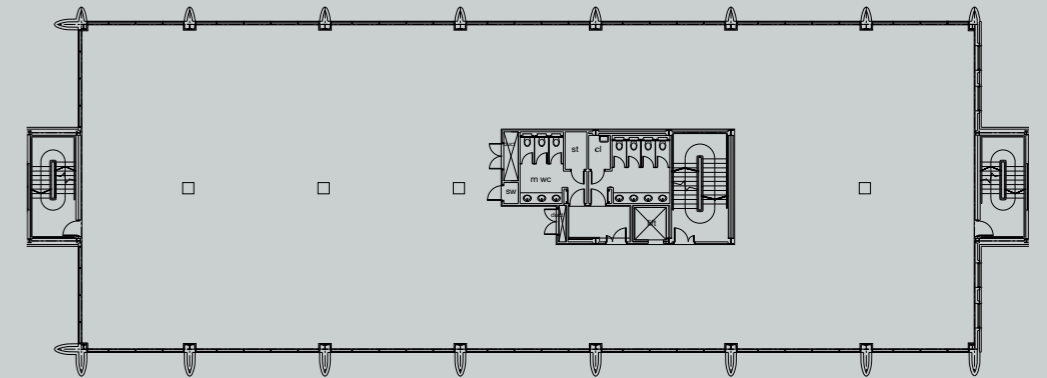

SECOND FLOOR

8,724 sq ft

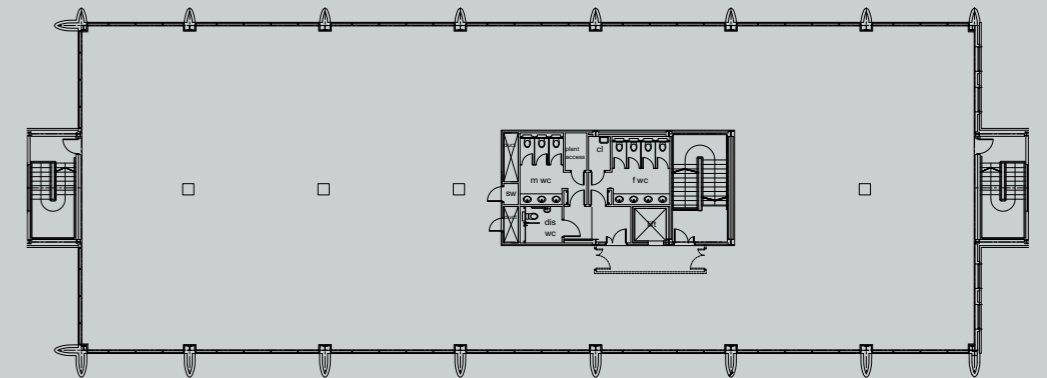

OXFORD ARC LIFE



Our community portal is available on your desktop or mobile app, bringing daily events, services, competitions to you and your colleagues. Whether you want to join us at a summer party, book a yoga class or book space in our business lounge – it is all here for you at Oxford ARC Life.



OXFORD WORKS



Oxford Works
Come and meet our Park Team at the Oxford Works, where you can hire a desk for an hour, a day or longer. With inspiring lounge space, phone booths and meeting rooms, it is the perfect work space that provides a refreshing alternative. There is also a fully equipped seminar theatre, all dedicated for our customers on Campus.



CAMPUS COMMUNITY



The Oxford Factory

At the Oxford Factory you can grab a coffee, hold an informal meeting or treat yourself to freshly baked pizza and other freshly cooked meals. Our contemporary restaurant serves the very best locally produced food and drink and can provide corporate catering to our seminar spaces or your workspace.

The Market Place

A vibrant social meeting place to grab a coffee at the Oxford Workshop, take time out to play some table tennis and enjoy the outdoor environment, relaxing in a deckchair on the lawns. For a hot chocolate in the winter sun or a bbq party in the summer, you can enjoy the Market Place all year round.



OCCUPIERS

Life Science Occupiers*

Accession Therapeutics*

ARGC

Animal Dynamics *

Audi Oxford

Blackberry Clinic

Bright Horizons

British Gas

Cancer Research*

Cluttons

Evov Therapeutics*

Exact Sciences*

Freeths

GRE

Harley Davidson

Ivy Farm*

Jazz Pharmaceutical*

NHS

Nielsen

Omass Therapeutics*

Oxbotica*

Oxfam

Oxford Biodynamics*

Oxford Biomedica*

Oxford County Council

Oxford Fertility

Oxford Management

Pennington Manches

Perspectum*

Pure Offices

Royal Mail

Spybiotech*

TI Automotive

Ultromics*

Wiley



TESTIMONIALS

"It's been a great experience working with Arlington to accommodate Perspectum's Oxford based staff into this newly renovated and modern space. We are looking forward to moving in so that our staff can benefit from all the Park has to offer."

Perspectum Diagnostics

"Our rapidly expanding business needed to acquire fully fitted lab space within a very short timeframe. The Arlington team at ARC Oxford stepped up to this challenge, finishing on time and to a very high standard – we are delighted with the result."

Evox Therapeutics

"ARC Oxford is already home to our manufacturing facility known as Oxbox, which is in operation for our viral vector manufacturing activities and also supporting the manufacturing of a COVID-19 vaccine candidate. In March 2020, as our activities and workforce expanded, we took the decision to relocate our corporate headquarters team from our existing HQ to a new office location on the Park. Arlington have helpfully accommodated all of our commercial requirements with the new office and we are delighted with the quality of the building and the wider environment."

Oxford BioMedica

CONTACT

DEVELOPER

ARC

David Williams

M: +44 (0)7443 887 500

E: david.williams@arcgroup.io

Dan Williams

M: +44 (0)7795 331925

E: dan.williams@arcgroup.io

www.arcgroup.io

LETTING AGENTS

JLL

Paddy Shipp

T: +44 (0)74691 55531

E: Paddy.Shipp@eu.jll.com

Bridget Partridge

T: +44 (0)7921 309816

E: Bridget.Partridge@eu.jll.com

Matthew Symons

T: +44 (0)7928 501324

E: Matthew.Symons@jll.com

www.jll.co.uk

Bidwells

Duncan May

M: +44 (0)7879 883886

E: duncan.may@bidwells.co.uk

Rob Beatson

M: +44 (0)7976 590996

E: robert.beatson@bidwells.co.uk

www.bidwells.co.uk

CBRE

Richard Venables

T: +44 (0)7816 491860

E: richard.venables@cbre.com

Kevin Wood

T: +44 (0)790 058 4150

E: kevin.wood@cbre.com

Charlotte Reaney

T: +44 (0)784 168 4842

E: charlotte.reaney@cbre.com

www.cbre.com

Misrepresentation Act

Advanced Research Clusters Ltd or JLL, CBRE and Bidwells give notice that these property particulars are provided as a general outline for guidance only. Intending purchasers or tenants should not rely on them as statements or representations of fact, but must satisfy themselves by inspection or otherwise as to their accuracy. As such, it does not constitute or form part of a contract. No person in the employ of Advanced Research Clusters Ltd or JLL, CBRE and Bidwells as representing agents of the property displayed has the authority to make or give any representation or warranty in relation to the property. Unless otherwise stated, all rents and prices quoted in these property particulars are exclusive of VAT which may be payable in addition to the amount quoted. Subject to contract. December 2022



**ARC
Oxford**