



SPACE

TO

FROM 1,537 SQ FT OF
CONTEMPORARY WORKSPACE

SHINE

THE LIGHTBOX

THE-LIGHTBOX.CO.UK

READING



Amazing space which can be configured to suit start-ups, SMEs and big businesses

The Lightbox is a striking landmark building located in Reading's town centre.

The building has been refurbished to offer contemporary high quality office space with exceptional parking and great opportunity to grow.

Occupiers include Barrett & Co Solicitors, Haines Watts and IT Talent.



SWITCHED

ON



FREELANCER



EARLY STAGE
TECH FOUNDER



STARTUP



LARGE
COMPANY



NON-PROFIT



SERVICE
PROVIDER



SMALL
BUSINESS



REMOTE
TEAM



The Lightbox Reading provides a stunning arrival into the brand new reception and business lounge facilities.





-  **RAISED FLOOR**
-  **2 X PASSENGER LIFTS**
-  **CONCIERGE**
-  **SECURITY**
-  **FROM 1,500 – 12,000 SQ FT**
-  **24 HOUR ACCESS**
-  **AIR CONDITIONING**
-  **EXPOSED SERVICES FINISH**
-  **SHOWER FACILITIES**
-  **KITCHEN AREA**
-  **CAR PARKING**
-  **LED LIGHTING**

ULTRA FLEXIBLE



The building is an exciting and inspiring place to work.
 For the commuter, facilities include showers and car parking at an excellent ratio of 1:426 sq ft.

- EXPOSED SERVICES**
- FLOOR TO CEILING GLAZING**
- NEW RECEPTION with concierge service**
- MALE FEMALE AND DISABLED WC FACILITIES**
- BUSINESS LOUNGE FACILITIES**
- EXCELLENT CAR PARKING RATIO**

Indicative fitout

- 48 x workstations
- 2 x informal meeting areas
- Reception area
- Kitchenette
- Break-out area
- 2 x meeting rooms
- 2 x offices
- Storage
- Printing area



THE LIGHTBOX

READING

AVAILABILITY

FLOOR	SQ FT	SQ M
Fourth	5,255	488
Third (part)	1,537	143
Second (Suite 1)	2,557	238
Second (Suite 2)	2,508	233
Total	11,857	1,102

Indicative full floor space plan

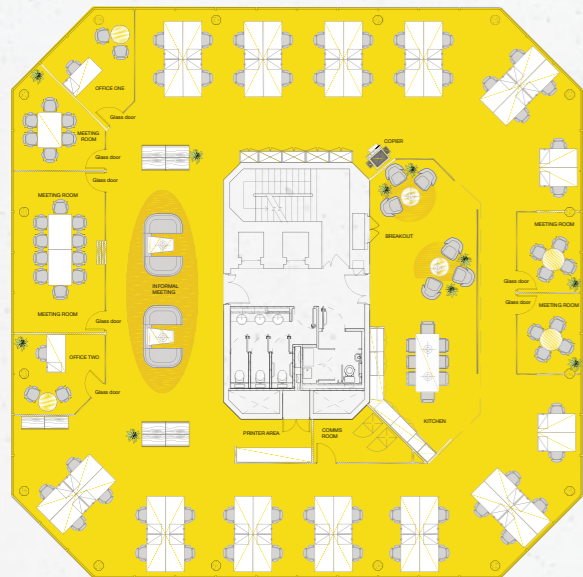

Fourth floor

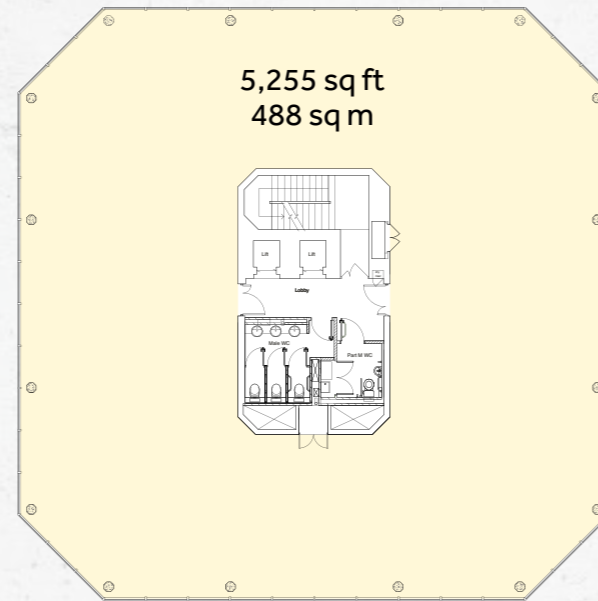

Third floor (part)

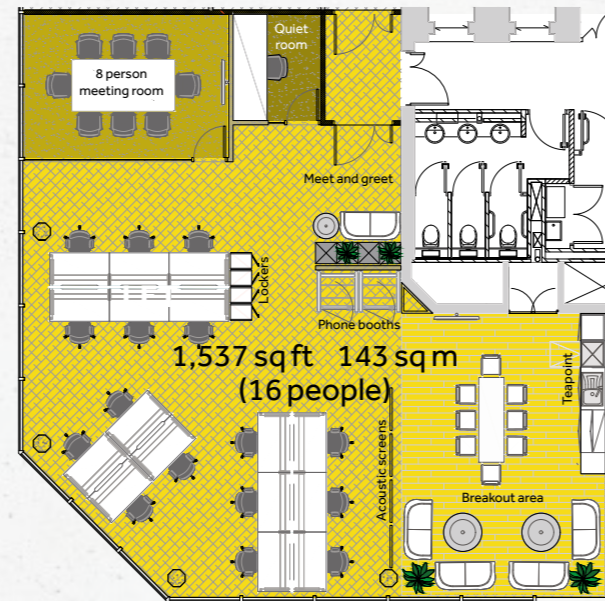

Indicative layout

Second floor

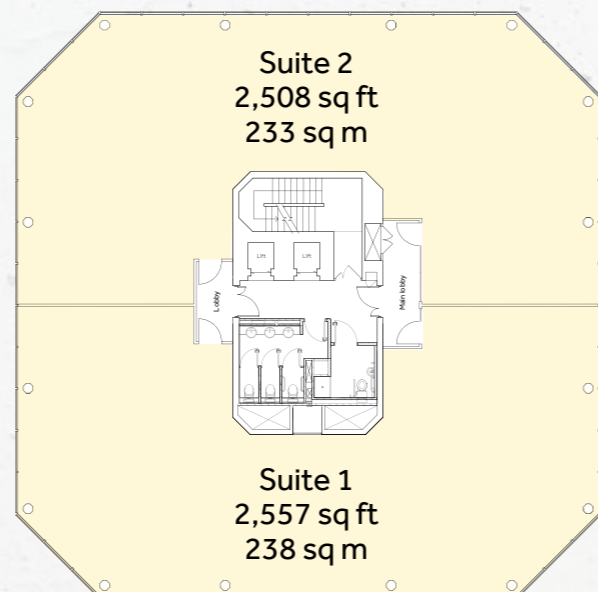

POSTCODE
RG1 7SN

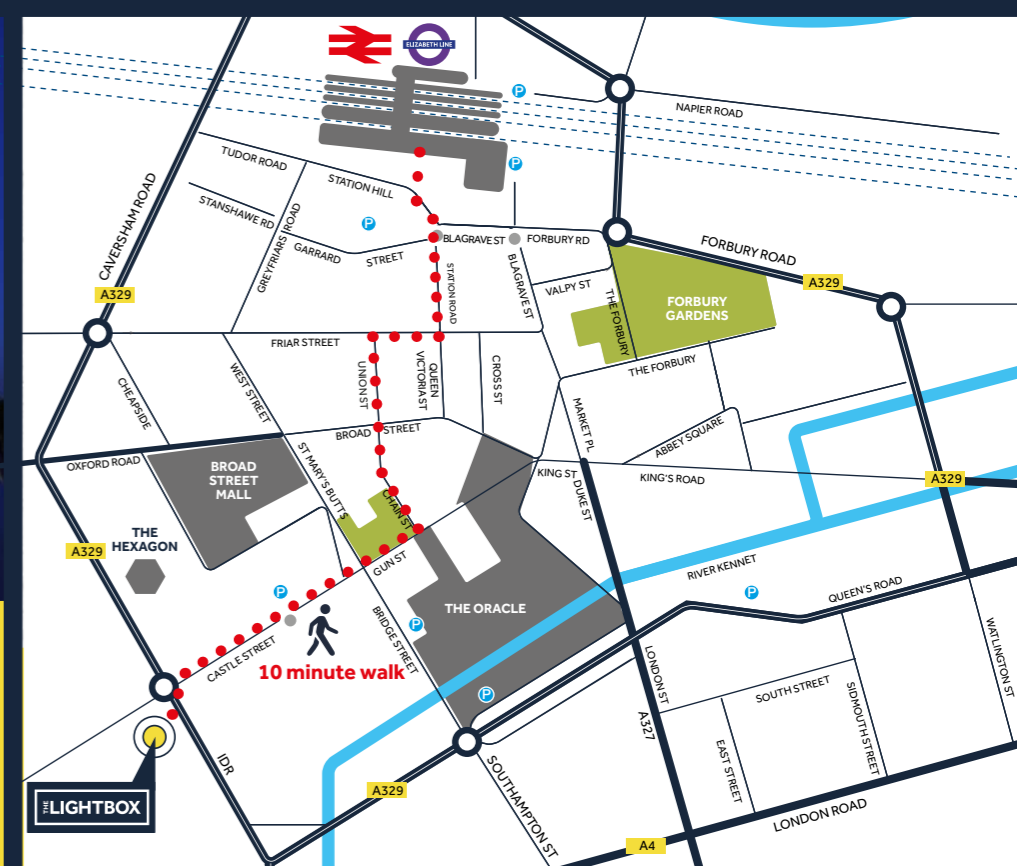
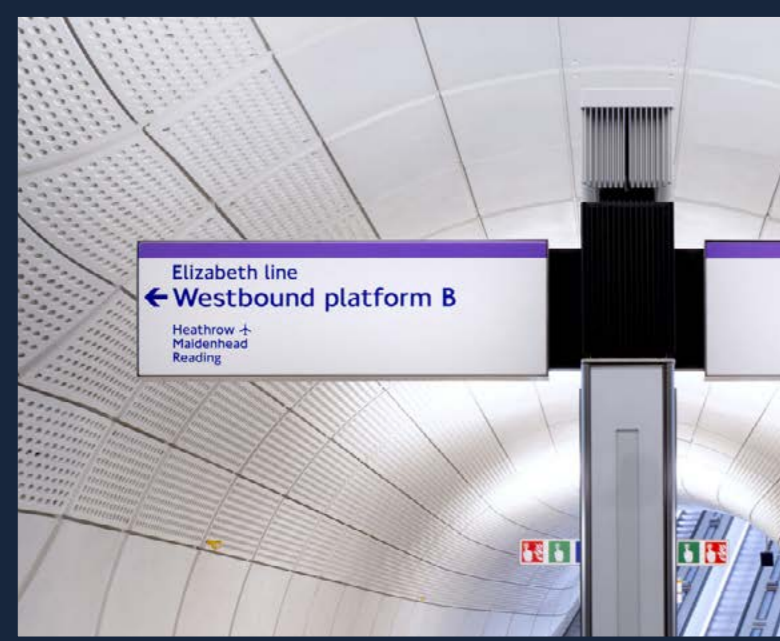

Reading is widely known as the 'capital of the Thames Valley' and is one of the most important commercial centres outside of London. The town is home to many major corporate occupiers, including Microsoft, SSE, Huawei and Prudential.

IGNITING

BUSINESS

The Lightbox is situated just 5 minutes' walk from the town centre's retail and leisure facilities, including The Oracle shopping centre, John Lewis, cafés and bars, and entertainment venues, such as the Hexagon Theatre and Vue cinema.

The town is the focal point for economic growth along the M4 motorway and is classed as one of the most vibrant urban centres in the UK.

Berkshire has a highly skilled and affluent catchment area which boasts excellent leisure and educational facilities as well as access to the beautiful surrounding countryside.



CONNECTIONS

Reading's strategic location, in the heart of the UK's transport network and its proximity to Heathrow and London, is one of its major attractions.



Reading railway station is one of the busiest rail hubs in Britain, connecting to London (Paddington and Waterloo) to the east, Birmingham to the north and Cardiff to the west.

Trains to London Paddington run every 10 minutes with a quickest journey time of 26 minutes.

The Elizabeth Line offers direct connections to the West End, the City and Canary Wharf.



Reading Train Station – 10 mins



Reading Train Station – 4 mins



M4 J11 – 4.9 miles – 12 mins

M4 J12 – 4.7 miles – 10 mins

London – 40 miles

Reading Train Station – 1 mile – 4 mins



Paddington – 26 mins

Birmingham – 1 hr 34 mins

Cardiff – 1 hr 23 mins



Heathrow – 21 miles (34 mins)

For more information please contact the joint agents:

Vail Williams
0118 909 7400
vailwilliams.com

Lambert Smith Hampton

Andrew Baillie
abaille@vailwilliams.com
07502 233770

Archie Chitty
07544 801888
achitty@lsh.co.uk

Arabella Macrae
amacrae@vailwilliams.com
07775 862913

Jay Moore
07772 064440
jamoore@lsh.co.uk



SHEIKH
HOLDINGS

MISREPRESENTATION: The Agents for themselves and for the vendors or lessors of this property give notice that: a) all particulars are set out as general outline only for the guidance of intending purchasers or lessees, and do not comprise part of an offer or contract; b) all descriptions, dimensions, references to condition and necessary permissions for use and occupation, and other details are given in good faith and are believed to be correct but any intending purchasers or tenants should not rely on them as statements or representations of fact but must satisfy themselves by inspection or otherwise as to the correctness of each of them. c) no person in the employment of the Agents has any authority to make any representation of warranty whatsoever in relation to this property. June 2023