



LEECHADWICK

SOLICITORS LLP
& ESTATE AGENTS



Laurel Drive

Southmoor

Price £295,000

Telephone 01993 703272 Email kr@lee-chadwick.co.uk

www.lee-chadwick.co.uk

Local Authority: Vale of White Horse District Council
Council Tax Band: C for 2024/2025 - Tenure: Freehold

A 2 Bedroom Semi-Detached Bungalow with Garage and side access to rear of property in the Popular Village of Southmoor in the Parish of Kingston Bagpuize.

The property comprises:

- Entrance Hall with cupboard
- Dining Room
- Living Room
- Two Bedrooms
- Main Bedroom comprising fitted wardrobe
- Bathroom with Airing Cupboard
- Driveway and Garage
- Front and Rear Gardens



Garage
Approx. Floor
Area 13.30 Sq.M.
(143 Sq.Ft.)

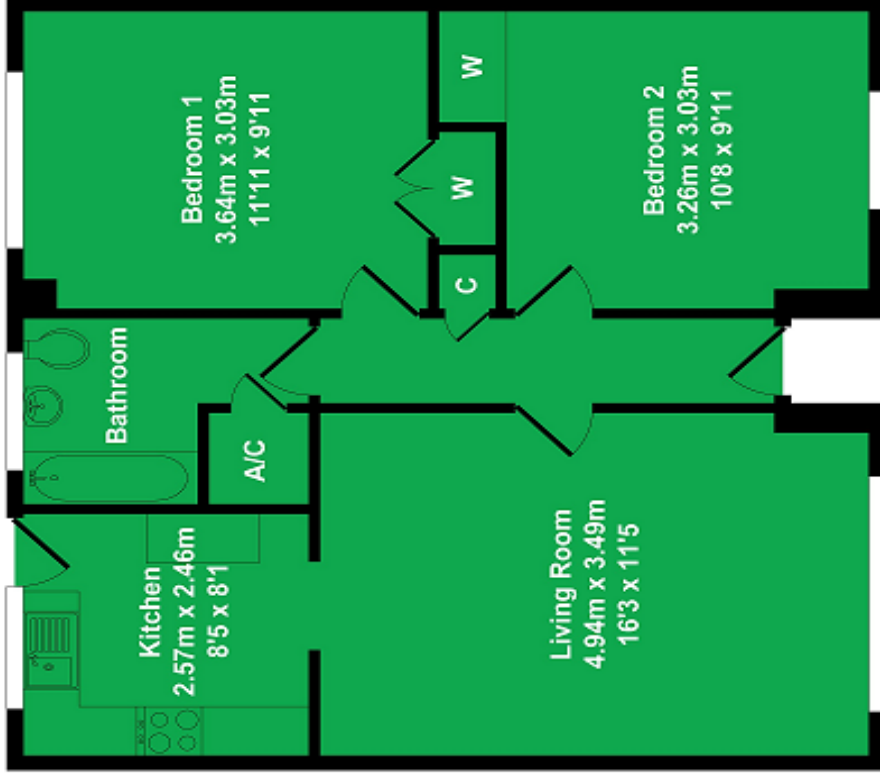

Ground Floor
Approx. Floor
Area 56.40 Sq.M.
(607 Sq.Ft.)

Total Approx. Floor Area 750 Sq.Ft. (69.7 Sq.M.)













Southmoor is a Popular Village in the Cotswolds just a short distance from the bustling market town of Abingdon. Southmoor benefits from a primary school and local Gastro Pub, The Waggon & Horses together with several local stores. A great location surrounded by the Cotswold countryside.

Disclaimer: Lee Chadwick endeavours to ensure that the floorplans, measurements and descriptions are accurate but cannot accept any responsibility for any errors, misstatements or omissions. In any event all measurements are approximate and these particulars are intended for guidance purposes only. Wide angled lenses may have been used for the photography. Lee Chadwick has not tested any appliances and purchasers should not assume that any reference to them means that they are included in the sale. It should not be assumed that any necessary planning or building regulation or listed building consents have been obtained. Any warranty or representation in relation to the property may not be relied upon. These particulars may not be included or relied upon in any offer nor may they form part of any contract. Purchasers must rely on their own inspection, legal enquiry and survey in all respects

Our ref: KR/HIL017.0005